

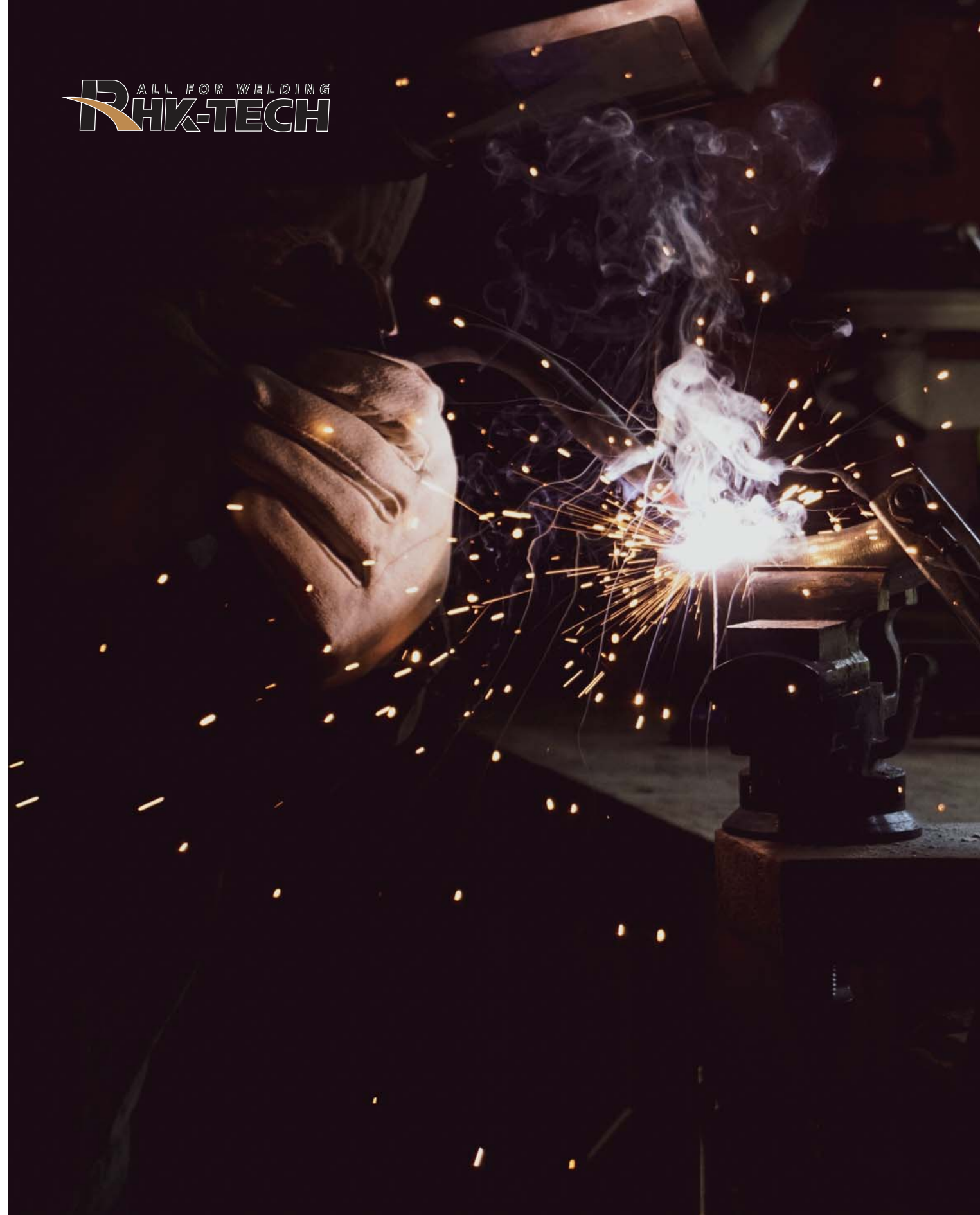

ALL FOR WELDING
RHK-TECH



WELDING TORCH

PRODUCT INTRODUCTION

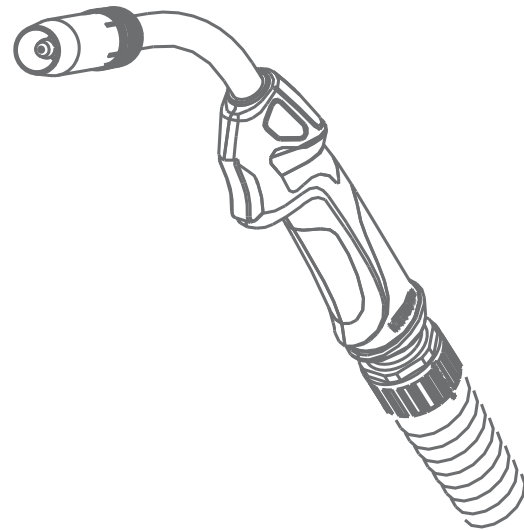

Company Introduction

RHK TECH Welding Machinery was established in 2013 as a professional partner for each distributor on Chinese market. With experience of the best manufacturers from Far East Market. RHK is the best provider to the steel fabrication, shipyards and related industries. We are excellent partner for distributors and final customers interested in welding consumables, personal safety, abrasives and all spare parts to welding equipment.

RHK TECH is a preferable professional partner for the customers looking for reliable supplier of welding solutions with best customer service form Far East.

We offer to our customers:

- Complete offer of welding Torches, Abrasive and personal safety products
- Qualified staff with easy communication in English
- Modern information systems implemented
- Developed and efficient logistics organization

We created a complete range of welding products and accessories, which helps our partners to find "cost alternative" and high quality goods as the alternative to international well-known manufacturers.



TORCH MINI 15



Technical data	技术参数
Cooling 冷却方式	Gas Cooled 气冷
Duty cycle 60% 负载率60%	180Amp CO ₂ , 150Amp MIX
Wire Size 焊丝直径	Φ0.6-1.0mm

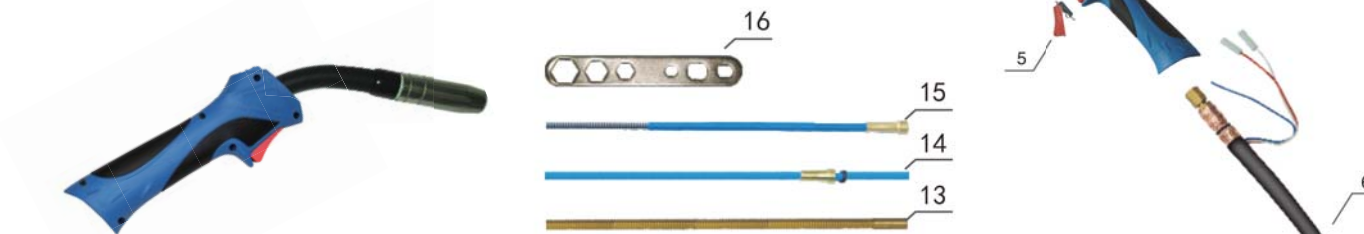

Position	Code	Ref.	
1	JDT0074	145.0075	
2	JDV0014-08	140.0059	Contact tip Φ 0.8mmE-CU/M6x25; 导电嘴 Φ 0.8mm/M6x25mm
3	JDA0098	002.0009	Torch head 15 with fitting; 15AK 枪颈 (含配件)
3.1	JAI0673	002.0078	Gas diffuser 15AK; 分流器 15AK
3.2	JGU0819	002.0058	Spring 15AK; 弹簧 15AK
4	JDW6061		MIG Mini handle black; 黑色迷你手柄 15AK
5	JIR0081	185.0031	Trigger; 焊枪用开关
6	JDO6771		Coaxial cable 3m; 同轴电缆组 3m
7	JIK0039		Front Cable Support; 电缆护套
8	JIK0656		Back box; 后把套
9	JGU0074		Screw M4x6; 螺丝 M4x6
10	JIK0074		Adaptor nut; 锁紧螺母
11	JUC0060	501.2155	Euro central adaptor body/air cooling; 欧式中央接头/空冷
12	JAU0082	501.0082	Liner nut; 送丝管锁紧螺母
13	JJD0231		Brass terminal Φ 2.0x4.0mm 0.35m; 铜送丝管 Φ 2.0x4.0mm/0.35m
14	JJD0111	126.0005	Teflon liner Φ 4.0x1.5mm 3m Blue; 特氟龙送丝管 Φ 4.0x1.5mm/3m/蓝色
15	JJD0511	124.0011	Blue liner Φ 0.6-0.8mm 3m; 带绝缘层送丝管 Φ 0.6-0.8mm/3m/蓝色
16	JDH6011		Spanner for MIG torches; MIG 焊枪扳手

Complete Torch

JDU2061		MIG MINI 15 torch 3m euro adaptor; MIG 15AK/3m/焊枪15AK/3m弹性针/欧式迷你手柄
JDU2067		MIG MINI 15 torch 4m euro adaptor; MIG 15AK/4m/焊枪15AK/4m弹性针/欧式迷你手柄
JDU2068		MIG MINI 15 torch 5m euro adaptor; MIG 15AK/5m/焊枪15AK/5m弹性针/欧式迷你手柄

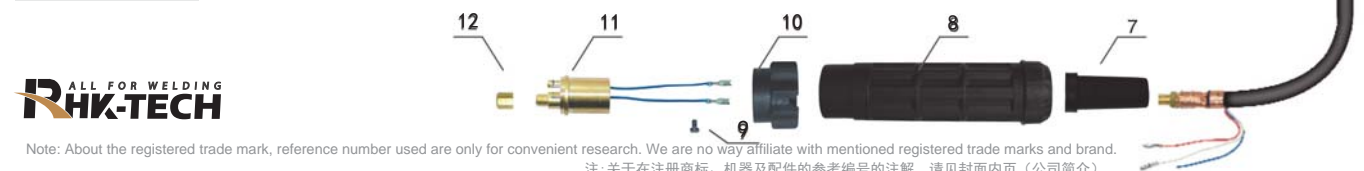

Note: About the registered trade mark, reference number used are only for convenient research. We are no way affiliate with mentioned registered trade marks and brand.
注: 关于在注册商标、机器及配件的参考编号的注解, 请见封面内页 (公司简介)

TORCH 15



Technical data	技术参数
Cooling 冷却方式	Gas Cooled 气冷
Duty cycle 60% 负载率60%	180Amp CO ₂ , 150Amp MIX
Wire Size 焊丝直径	Φ 0.6-1.0mm

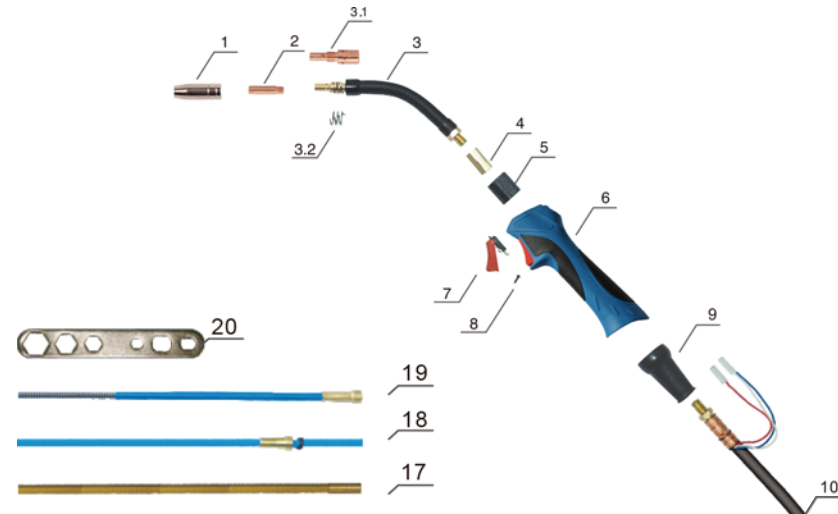

Position	Code	Ref.	Description
1	JDT0074	145.0075	Gas nozzle Φ 12mm; 喷嘴 Φ 12mm
2	JDV0014-08	140.0059	Contact tip Φ 0.8mm E-CU/M6x25; 导电嘴 Φ 0.8mm/M6x25mm
3	JDA0098	002.0009	Torch head 15 with fitting; 15AK 枪颈 (含配件)
3.1	JAI0673	002.0078	Gas diffuser 15AK; 分流器 15AK
3.2	JGU0819	002.0058	Spring 15AK; 弹簧 15AK
4	JAI0678		Hexagonal fitting; 六角适配器
5	JIK0041-01		Plastic Body; 塑料适配器
6	JDW0801-01		MIG handle Blue/Grip; MIG手柄/蓝色
7	JIR0081	185.0031	Trigger; 焊枪用开关
8	JGU0885		Screw M3x10; 螺丝 M3x10
9	JIK0793		Joint for 15; 电缆支撑用球节 15枪用
10	JDO0674	160.0065	Coaxial cable 3m; 同轴电缆组3m
11	JIK0726		Housing for handle; 手柄锁紧环
12	JIK0714		Back box; 后把套
13	JGU0074		Screw M4x6; 螺丝 M4x6
14	JIK0074		Adaptor nut; 焊枪锁紧螺母/塑料螺纹
15	JUC0060	501.2155	Euro central adaptor body/air cooling; 欧式中央接头/空冷
16	JAU0082	501.0082	Liner nut; 送丝管锁紧螺母
17	JJD0231		Brass terminal Φ 2.0x4.0mm 0.35m; 铜送丝管 Φ 2.0x4.0mm/0.35m
18	JJD0111	126.0005	Teflon liner Φ 4.0x1.5mm 3m Blue; 特氟龙送丝管 Φ 4.0x1.5mm/3m/蓝色
19	JJD0511	124.0011	Blue liner Φ 0.6-0.8mm 3m; 带绝缘层送丝管 Φ 0.6-0.8mm/3m/蓝色
20	JDH6011		Spanner for MIG torches; MIG焊枪扳手

Complete Torch

JDU2009-36	MIG 15AK torch 3m euro adaptor /spring pins; 焊枪15AK/3m/弹性针
JDU2000-36	MIG 15AK torch 4m euro adaptor /spring pins; 焊枪15AK/4m/弹性针
JDU2006-36	MIG 15AK torch 5m euro adaptor /spring pins; 焊枪15AK/5m/弹性针

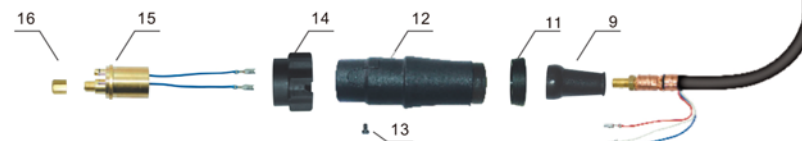

Note: About the registered trade mark, reference number used are only for convenient research. We are no way affiliate with mentioned registered trade marks and brand.
注: 关于在注册商标、机器及配件的参考编号的注解, 请见封面内页 (公司简介)

TORCH 24



Technical data	技术参数
Cooling 冷却方式	Gas Cooled 气冷
Duty cycle 60% 负载率60%	250Amp CO ₂ , 220Amp MIX
Wire Size 焊丝直径	Φ 0.8-1.2mm

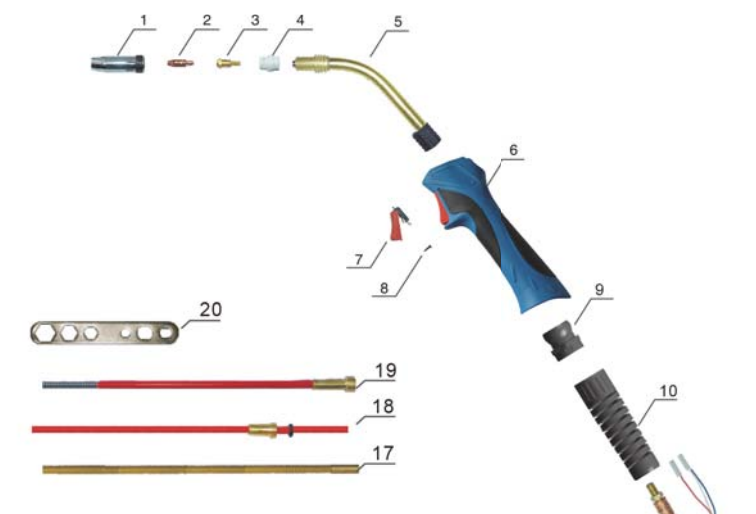

Position	Code	Ref.	Description
1	JDT0817	145.0080	Gas nozzle Φ 12.5mm; 喷嘴 Φ 12.5mm
2	JDV0014-10	140.0253	Contact tip Φ 1.0mm E-CU/M6x25; 导电嘴 Φ 1.0mm/M6x25mm
3	JDV0694	142.0003	Contact tip holder 24KD M6x26mm; 导电嘴座/24KD/M6x26mm
4	JDG0540	012.0183	White ceramic gas diffuser 24KD; 白色陶瓷分流器 24KD
5	JDA0641	012.0001	Torch head 24KD; 枪颈 24KD
6	JDW0801-01		MIG handle Blue/Grip; MIG手柄/蓝色
7	JIR0081	185.0031	Trigger; 焊枪用开关
8	JGU0885		Screw M3x10; 螺丝 M3x10
9	JIK0032		Joint for MIG handle; MIG手柄用球头
10	JGU0893		Spring for cable support; 电缆支撑弹簧
11	JDO0775		Coaxial cable 3m; 同轴电缆组 3m
12	JIK0714		Back box; 后把套
12.1	JIK0726		Housing for handle; 手柄锁紧环
13	JGU0074		Screw M4x6; 螺丝 M4x6
14	JIK0083		Adaptor nut; 焊枪锁紧螺母/蓝色
15	JUC0060	501.2155	Euro central adaptor body/air cooling; 欧式中央接头/空冷
16	JAU0082	501.0082	Liner nut; 送丝管锁紧螺母
17	JJD0231		Brass terminal Φ 2.0x4.0mm 0.35m; 铜送丝管 Φ 2.0x4.0mm/0.35m
18	JJD0171	126.0021	Teflon liner Φ 2.0x4.0mm 3m Red; 特氟龙送丝管 Φ 2.0x4.0mm/3m/红色
19	JJD0571	124.0026	Red liner Φ 1.0-1.2mm 3m; 带绝缘层送丝管 Φ 1.0-1.2mm/3m/红色
20	JDH6011		Spanner for MIG torches; MIG焊枪扳手

Complete Torch

JDU2609-36	MIG 24KD torch 3m euro adaptor /spring pins; 焊枪24KD/3m/弹性针
JDU2600-36	MIG 24KD torch 4m euro adaptor /spring pins; 焊枪24KD/4m/弹性针
JDU2606-36	MIG 24KD torch 5m euro adaptor /spring pins; 焊枪24KD/5m/弹性针



Note: About the registered trade mark, reference number used are only for convenient research. We are no way affiliate with mentioned registered trade marks and brand.
注: 关于在注册商标、机器及配件的参考编号的注解, 请见封面内页 (公司简介)

TORCH 25



Technical data	技术参数
Cooling 冷却方式	Gas Cooled 气冷
Duty cycle 60% 负载率60%	230Amp CO ₂ , 200Amp MIX
Wire Size 焊丝直径	Φ0.8-1.2mm

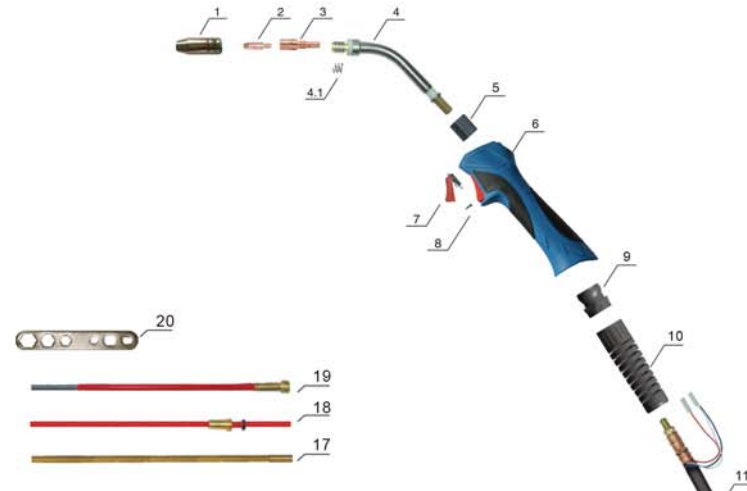

Position	Code	Ref.	Description
1	JDT0089	145.0100	Gas nozzle Φ 15mm; 喷嘴 Φ 15mm
2	JDV0015-10	140.0242	Contact tip Φ 1.0mm E-CU/M6x28; 导电嘴 Φ 1.0mm/M6x28mm
3	JDG0072	142.0001	Gas diffuser M6x35mm; 分流器 M6x35mm/25AK
4	JDA0099	004.0012	Torch head 25AK; 枪颈 25AK
4.1	JGU0810	003.0013	Spring 25AK; 弹簧 25AK
5	JIK0041-01	400.0044	Plastic Body; 塑料适配器
6	JDW0801-01		MIG handle Blue/Grip; MIG手柄/蓝色
7	JIR0081	185.0031	Trigger; 焊枪用开关
8	JGU0885		Screw M3x10; 螺丝 M3x10
9	JIK0032		Joint for MIG handle; MIG手柄用球头
10	JGU0893		Spring for cable support; 电缆支撑弹簧
11	JDO0675		Coaxial cable 3m; 同轴电缆组3m
12	JIK0714		Back box; 后把套
12.1	JIK0726		Housing for handle; 手柄锁紧环
13	JGU0074		Screw M4x6; 螺丝 M4x6
14	JIK0083		Adaptor nut; 焊枪锁紧螺母/蓝色
15	JUC0060	501.2155	Euro central adaptor body/air cooling; 欧式中央接头/空冷
16	JAU0082	501.0082	Liner nut; 送丝管锁紧螺母
17	JJD0231		Brass terminal Φ 2.0x4.0mm 0.35m; 铜送丝管 Φ 2.0x4.0mm/0.35m
18	JJD0171	126.0021	Teflon liner Φ 2.0x4.0mm 3m Red; 特氟龙送丝管 Φ 2.0x4.0mm/3m/红色
19	JJD0571	124.0026	Red liner Φ 1.0-1.2mm 3m; 带绝缘层送丝管 Φ 1.0-1.2mm/3m/红色
20	JDH6011		Spanner for MIG torches; MIG焊枪扳手
Complete Torch			
	JDU2709-36		MIG 25AK torch 3m euro adaptor /spring pins; 焊枪25AK/3m/弹性针
	JDU2700-36		MIG 25AK torch 4m euro adaptor /spring pins; 焊枪25AK/4m/弹性针
	JDU2706-36		MIG 25AK torch 5m euro adaptor /spring pins; 焊枪25AK/5m/弹性针



Note: About the registered trade mark, reference number used are only for convenient research. We are no way affiliate with mentioned registered trade marks and brand.
注: 关于在注册商标、机器及配件的参考编号的注解, 请见封面内页 (公司简介)

TORCH 26

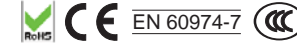

Technical data	技术参数
Cooling 冷却方式	Gas Cooled 气冷
Duty cycle 60% 负载率60%	290Amp CO ₂ , 260Amp MIX
Wire Size 焊丝直径	Φ0.8-1.2mm

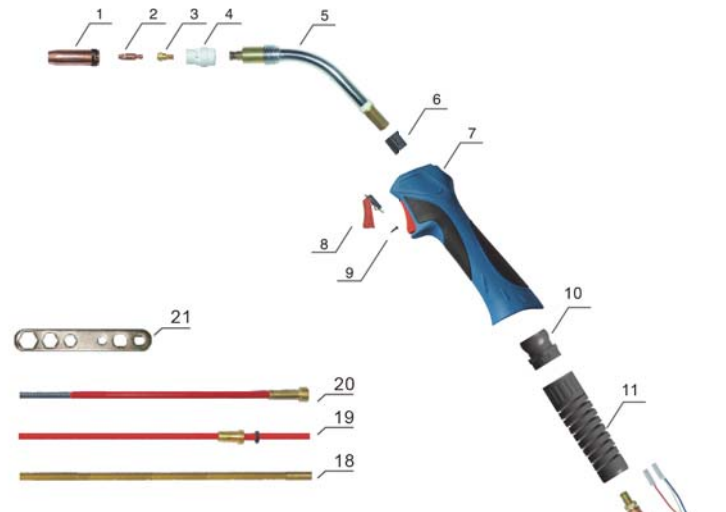

Position	Code	Ref.	Description
1	JDT0724	145.0085	Gas nozzle Φ 16mm; 喷嘴 Φ 16mm
2	JDV0015-10	140.0242	Contact tip Φ 1.0mm E-CU/M6x28mm; 导电嘴 Φ 1.0mm/M6x28mm
3	JDV0027	142.0007	Contact tip holder M6x22mm; 导电嘴座/M6x22mm
4	JDG0546	018.0141	White ceramic gas diffuser 26KD; 白色陶瓷分流器 26KD
5	JDA0647	018.0001	Torch head 26KD; 枪颈 26KD
6	JIK0041-01	400.0044	Plastic Body; 塑料适配器
7	JDW0801-01		MIG handle Blue/Grip; MIG手柄/蓝色
8	JIR0081	185.0031	Trigger; 焊枪用开关
9	JGU0885		Screw M3x10; 螺丝 M3x10
10	JIK0032		Joint for MIG handle; MIG手柄用球头
11	JGU0893		Spring for cable support; 电缆支撑弹簧
12	JDO0607	160.0239	Coaxial cable 3m; 同轴电缆组3m
13	JIK0714		Back box; 后把套
13.1	JIK0726		Housing for handle; 手柄锁紧环
14	JGU0074		Screw M4x6; 螺丝 M4x6
15	JIK0083		Adaptor nut; 焊枪锁紧螺母
16	JUC0060	501.2155	Euro central adaptor body/air cooling; 欧式中央接头/空冷
17	JAU0082	501.0082	Liner nut; 送丝管锁紧螺母
18	JJD0231		Brass terminal Φ 2.0x4.0mm 0.35m; 铜送丝管 Φ 2.0x4.0mm/0.35m
19	JJD0171	126.0021	Teflon liner Φ 2.0x4.0mm 3m Red; 特氟龙送丝管 Φ 2.0x4.0mm/3m/红色
20	JJD0571	124.0026	Red liner Φ 1.0-1.2mm 3m; 带绝缘层送丝管 Φ 1.0-1.2mm/3m/红色
21	JDH6011		Spanner for MIG torches; MIG焊枪扳手
Complete Torch			
	JDU2809-36		MIG 26KD torch 3m euro adaptor /spring pins; 焊枪26KD/3m/弹性针
	JDU2800-36		MIG 26KD torch 4m euro adaptor /spring pins; 焊枪26KD/4m/弹性针
	JDU2806-36		MIG 26KD torch 5m euro adaptor /spring pins; 焊枪26KD/5m/弹性针



Note: About the registered trade mark, reference number used are only for convenient research. We are no way affiliate with mentioned registered trade marks and brand.
注: 关于在注册商标、机器及配件的参考编号的注解, 请见封面内页 (公司简介)

TORCH 36



Technical data	技术参数
Cooling 冷却方式	Gas Cooled 气冷
Duty cycle 60% 负载率60%	340Amp CO ₂ , 300Amp MIX
Wire Size 焊丝直径	Φ0.8-1.6mm

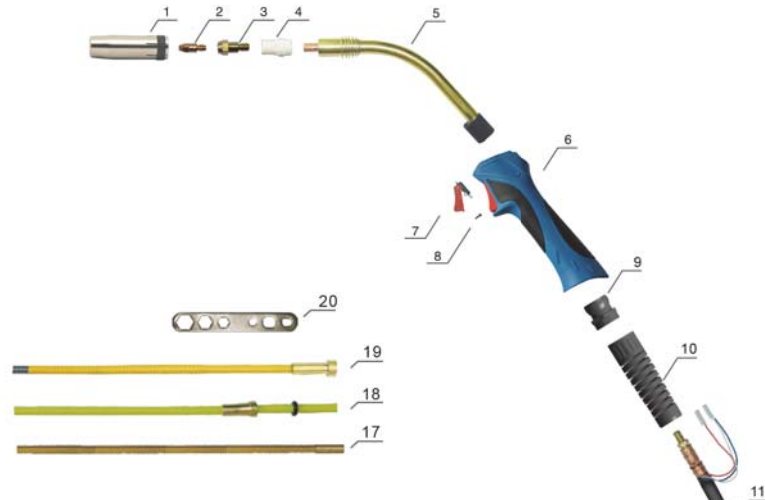

Position	Code	Ref.	Description
1	JDT0083	145.0078	Gas nozzle Φ 16mm ; 喷嘴 Φ 16mm
2	JDV0015-12	140.0379	Contact tip Φ 1.2mm E-CU/M6x28 ; 导电嘴 Φ 1.2mm/M6x28mm
3	JDV0697	142.0011	Contact tip holder M6x32mm ; 导电嘴座/M6x32mm
4	JDG0573	014.0023	White ceramic gas diffuser ; 白色陶瓷分流器 36KD
5	JDA0090	014.0006	Torch head 36KD ; 枪颈 36KD
6	JDW0801-01		MIG handle Blue/Grip ; MIG手柄/蓝色
7	JIR0081	185.0031	Trigger ; 焊枪用开关
8	JGU0885		Screw M3x10 ; 螺丝 M3x10
9	JIK0032		Joint for MIG handle ; MIG手柄用球头
10	JGU0893		Spring for cable support ; 电缆支撑弹簧
11	JDO0681	160.0364	Coaxial cable 3m ; 同轴电缆组3m
12	JIK0714		Back box ; 后把套
12.1	JIK0726		Housing for handle ; 手柄锁紧环
13	JGU0074		Screw M4x6 ; 螺丝 M4x6
14	JIK0083		Adaptor nut ; 焊枪锁紧螺母/蓝色
15	JUC0060	501.2155	Euro central adaptor body/air cooling ; 欧式中央接头/空冷
16	JAU0082	501.0082	Liner nut ; 送丝管锁紧螺母
17	JJD0237		Brass terminal Φ 3.0x4.5mm 0.35m ; 铜送丝管 Φ 3.0x4.5mm/0.35m
18	JJD0221	126.0039	Teflon liner Φ 3.0x4.5mm 3m Yellow ; 特氟龙管 Φ 3.0x4.5mm/3m/黄色
19	JJD0501	124.0041	Yellow liner Φ 1.2-1.6mm 3m ; 带绝缘层送丝管 Φ 1.2-1.6mm/3m/黄色
20	JDH6011		Spanner for MIG torches ; MIG 焊枪扳手

Complete Torch

JDU2909-36	MIG 36KD torch 3m euro adaptor/spring pins ; 焊枪36KD/3m/弹性针
JDU2900-36	MIG 36KD torch 4m euro adaptor/spring pins ; 焊枪36KD/4m/弹性针
JDU2906-36	MIG 36KD torch 5m euro adaptor/spring pins ; 焊枪36KD/5m/弹性针



Note: About the registered trade mark, reference number used are only for convenient research. We are no way affiliate with mentioned registered trade marks and brand.
注: 关于在注册商标、机器及配件的参考编号的注解, 请见封面内页 (公司简介)

TORCH 40



Technical data	技术参数
Cooling 冷却方式	Gas Cooled 气冷
Duty cycle 60% 负载率60%	380Amp CO ₂ , 360Amp MIX
Wire Size 焊丝直径	Φ1.0-2.4mm

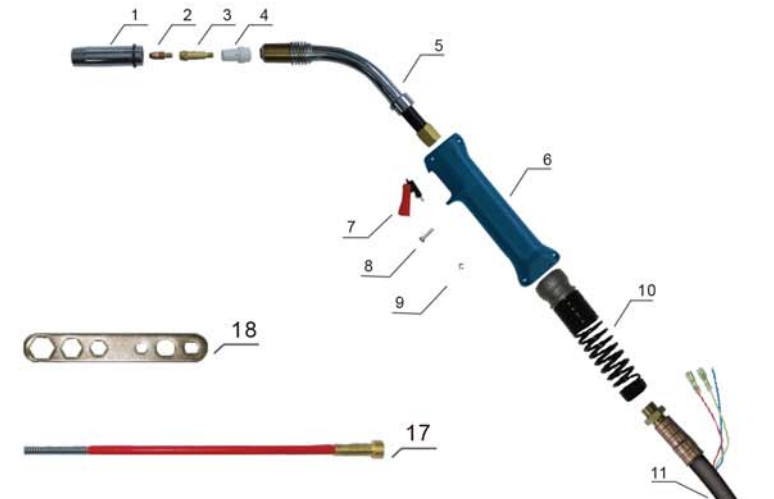

Position	Code	Ref.	Description
1	JDT0711	145.0079	Gas nozzle Φ 18mm 40KD ; 喷嘴 Φ 18mm 40KD
2	JDV0016-16	140.0587	Contact tip 1.6/M8x30mm ; 导电嘴 1.6/M8x30mm
3	JDV0038	142.0025	Contact tip holder 40KD/M8/47mm ; 导电嘴座 40KD/M8/47mm
4	JDG0542	015.0023	White ceramic gas diffuser 40KD ; 陶瓷分流器 40KD
5	JDA0093	015.0001	Torch head 40KD 50° ; 枪颈 40KD 50°
6	JDW0811		MIG handle 40KD Blue ; MIG手柄 40KD/蓝色
7	JIR0081	185.0031	Trigger 21.8mm ; 开关 21.8mm
8	JGU0089		Screw M4x14 ; 螺丝 M4x14
9	JGU0031		Nut M4 UNI 5587 (Sp 4) ; 六角螺母 M4
10	JAI0875		Joint with spring ; 带弹簧球节
11	JDO0620		Coaxial cable 3m ; 同轴电缆 3m
12	JIK0724		Back box for air cooling for ; 空冷枪后把套
13	JGU0074		Screw M4x6 UNI 6107 ; 螺丝 M4x6 UNI 6107
14	JIK0081		Gun plug nut ; 焊枪锁紧螺母
15	JUC0020		Euro central adaptor body/40KD/spring pins/Adaptor nut ; 欧式中央接头 40KD/弹性针
16	JAU0082	501.0082	Liner nut ; 送丝管锁紧螺母
17	JJD0501	124.0041	Insulated steel liner 1.2-1.6/3m/Yellow ; 带绝缘层送丝管 1.2-1.6 3m/黄色
18	JDH6011		Spanner for MIG torches ; MIG 焊枪扳手

Complete Torch

JDU2109	MIG 40KD torch 3m with /spring pins ; 焊枪40KD/3m/弹性针
JDU2100	MIG 40KD torch 4m with /spring pins ; 焊枪40KD/4m/弹性针
JUD2106	MIG 40KD torch 5m with /spring pins ; 焊枪40KD/5m/弹性针



Note: About the registered trade mark, reference number used are only for convenient research. We are no way affiliate with mentioned registered trade marks and brand.
注: 关于在注册商标、机器及配件的参考编号的注解, 请见封面内页 (公司简介)

TORCH 240



Technical data	技术参数
Cooling 冷却方式	Water Cooled 水冷
Duty cycle 100% 暂载率100%	300Amp CO ₂ , 270Amp MIX
Wire Size 焊丝直径	Φ 0.8-1.2mm

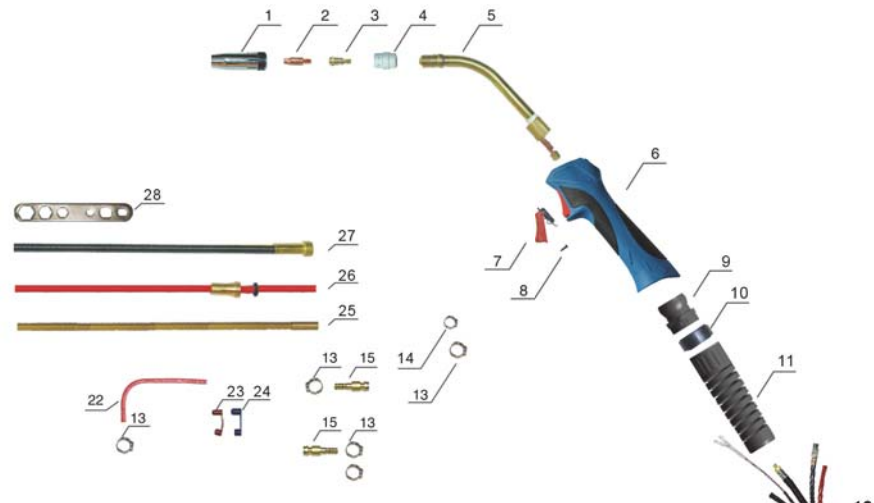

Position	Code	Ref.	Description
1	JDT0817	145.0080	Gas nozzle Φ 12.5mm; 喷嘴 Φ 12.5mm
2	JDV0014-10	140.0253	Contact tip Φ 1.0mm E-CU/M6x25; 导电嘴 Φ 1.0mm/M6x25mm
3	JDV0694	142.0003	Contact tip holder M6x26mm; 导电嘴座/M6x26mm
4	JDG0540		White ceramic gas diffuser; 白色陶瓷分流器 24KD
5	JDJ0002	023.0001	Torch head 240; 枪头 240
6	JDW0801-01		MIG handle Blue/Grip; MIG手柄/蓝色
7	JIR0081	185.0031	Trigger; 焊枪用开关
8	JGU0885		Screw M3x10; 螺丝 M3x10
9	JIK0032		Joint for MIG handle; MIG手柄用球头
10-1	JIK0863		HOUSING RING/BIG/INSIDE; 锁紧内环/大
10-2	JIK0866		HOUSING FOR PLASMA BACK BOX/BIG; 等离子后把套用锁紧环/大
11	JGU0833		Spring for cable support; 电缆支撑弹簧
12	JDE0078		Cable assembly 3m 401D-501D; 水冷电缆组 3m/401D-501D
13	JGU0733		Clamp Φ 9.5; 卡箍 Φ 9.0
14	JGU0741		Clamp Φ 8.7; 卡箍 Φ 8.0
15	JAU8081	501.0114	Quick connector water Φ 6mm; 水冷快速插头 Φ 6mm
16	JIK0774		Back box for water cooled; 水冷枪后把套
17	JIK0775		Hose support for water cooled rear box; 水冷枪后把套用水管支柱
18	JGU0074		Screw M4x6; 螺丝 M4x6
19	JIK0083		Adaptor nut/Blue; 焊枪锁紧螺母/蓝色
20	JUC0068	501.2156	Euro central adaptor body/water cooling; 欧式水冷中央接头/水冷
21	JAU0082	501.0082	Liner nut; 送丝管锁紧螺母
22	JLI0616		Output water tube M5x8mm 0.8m Red; EPDM 编织管 M5x8mm 0.8m/红色
23	JIK0317		Plastic support for water cooling connector /Red; 水堵/红色
24	JIK0319		Plastic support for water cooling connector /Blue; 水堵/蓝色
25	JJD0231		Brass terminal Φ 2.0x4.0mm 0.35m; 铜送丝管 Φ 2.0x4.0mm/0.35m
26	JJD0171	126.0005	Teflon liner Φ 2.0x4.0mm 3m Red; 特氟龙管 Φ 2.0x4.0mm/3m/红色
27	JJD0582	122.0031	Steel liner Φ 1.0-1.2mm 3m; 钢送丝管 Φ 1.0-1.2mm/3m
28	JDH6011		Spanner for MIG torches; MIG 焊枪扳手
Complete Torch			
	JDI2509-36		MIG 240 torch 3m euro adaptor/spring pins; 焊枪240/3m/弹性针
	JDI2500-36		MIG 240 torch 4m euro adaptor/spring pins; 焊枪240/4m/弹性针
	JDI2506-36		MIG 240 torch 5m euro adaptor/spring pins; 焊枪240/5m/弹性针



Note: About the registered trade mark, reference number used are only for convenient research. We are no way affiliate with mentioned registered trade marks and brand.
注: 关于在注册商标、机器及配件的参考编号的注解, 请见封面内页 (公司简介)

TORCH 400/500



Technical data	技术参数400
Cooling 冷却方式	Water Cooled 水冷
Duty cycle 100% 暂载率100%	400Amp CO ₂ , 350Amp MIX
Wire Size 焊丝直径	Φ 0.8-1.2mm

Technical data 500	技术参数500
Cooling 冷却方式	Water Cooled 水冷
Duty cycle 100% 暂载率100%	500Amp CO ₂ , 450Amp MIX
Wire Size 焊丝直径	Φ 1.0-1.6mm

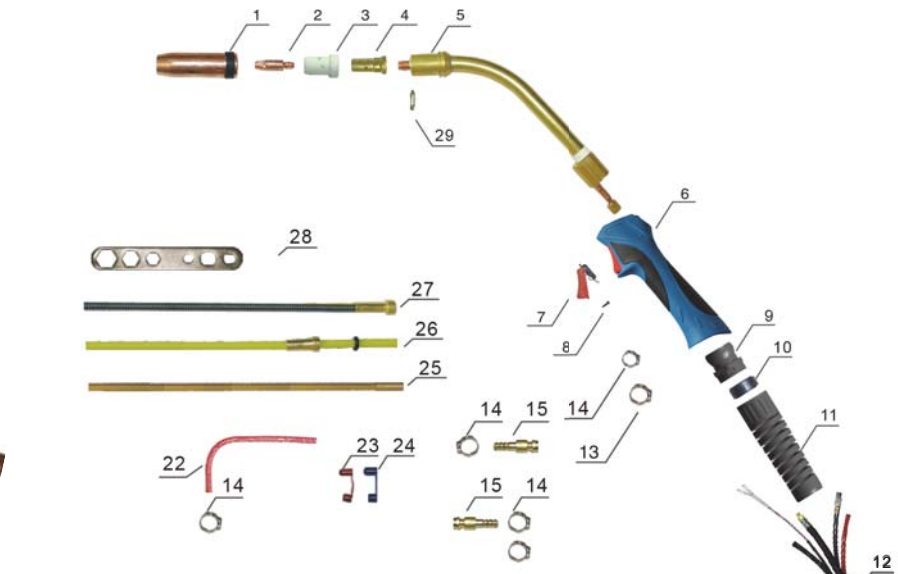

Position	Code	Ref.	Description
1	JDT0724	145.0085	Gas nozzle Φ 16mm; 喷嘴 Φ 16mm
2	JDV0016-12	140.0442	Contact tip Φ 1.2mm E-CU/M8x30; 导电嘴 Φ 1.2mm/M8x30mm
3	JDG0535	030.0190	White ceramic gas diffuser; 白色陶瓷分流器 401D-501D
4	JDG0032	142.0022	Contact tip holder M8x25mm; 导电嘴座/M8x25mm
5			Torch head; 枪头
5.1	JDJ0066	034.0001	Torch head 501D; 枪头 501D
5.2	JDJ0060	033.0001	Torch head 401D; 枪头 401D
6	JDW0801-01		MIG handle Blue/Grip; MIG手柄/蓝色
7	JIR0081	185.0031	Trigger; 焊枪用开关
8	JGU0885		Screw M3x10; 螺丝 M3x10
9	JIK0032		Joint for MIG handle; MIG手柄用球头
10-1	JIK0863		HOUSING RING/BIG/INSIDE; 锁紧内环/大
10-2	JIK0866		HOUSING FOR PLASMA BACK BOX/BIG; 等离子后把套用锁紧环/大
11	JGU0833		Spring for cable support; 电缆支撑弹簧
12	JDE0078		Cable assembly 3m 401D-501D; 水冷电缆组 3m/401D-501D
13	JGU0733		Clamp Φ 9.5; 卡箍 Φ 9.0
14	JGU0741		Clamp Φ 8.7; 卡箍 Φ 8.0
15	JAU8081	501.0114	Quick connector water Φ 6mm; 水冷快速插头 Φ 6mm
16	JIK0775		Hose support for water cooled rear box; 水冷枪后把套用水管支柱
17	JGU0074		Screw M4x6; 螺丝 M4x6
18	JIK0774		Back box for water cooled; 水冷枪后把套
19	JIK0083		Adaptor nut/Blue; 焊枪锁紧螺母/蓝色
20	JUC0068	501.2156	Euro central adaptor body/water cooling; 欧式水冷中央接头/水冷
21	JAU0082	501.0082	Liner nut; 送丝管锁紧螺母
22	JLI0616		Output water tube M5x8mm 0.8m red; EPDM 编织管 M5x8mm 0.8m/红色
23	JIK0317		Plastic support for water cooling connector /Red; 水堵/红色
24	JIK0319		Plastic support for water cooling connector /Blue; 水堵/蓝色
25	JJD0237		Brass terminal Φ 3.0x4.5mm 0.35m; 铜送丝管 Φ 3.0x4.5mm/0.35m
26	JJD0221	126.0039	Teflon liner Φ 3.0x4.5mm 3m Yellow; 特氟龙管 Φ 3.0x4.5mm/3m/黄色
27	JJD0591	122.0056	Steel liner Φ 1.2-1.6mm 3m; 钢送丝管 Φ 1.2-1.6mm/3m
28	JDH6011		Spanner for MIG torches; MIG 焊枪扳手
29	JAI6734	030.0019	Insulator 401D-501D; 绝缘垫片 401D-501D
Complete Torch			
	JDI2209-36		MIG 401D torch 3m euro adaptor/spring pins; 焊枪401D/3m/弹性针
	JDI2200-36		MIG 401D torch 4m euro adaptor/spring pins; 焊枪401D/4m/弹性针
	JDI2206-36		MIG 401D torch 5m euro adaptor/spring pins; 焊枪401D/5m/弹性针
	JDI2209-36		MIG 501D torch 3m euro adaptor/spring pins; 焊枪501D/3m/弹性针
	JDI2300-36		MIG 501D torch 4m euro adaptor/spring pins; 焊枪501D/4m/弹性针
	JDI2306-36		MIG 501D torch 5m euro adaptor/spring pins; 焊枪501D/5m/弹性针

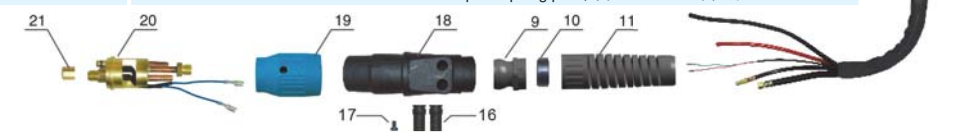

Note: About the registered trade mark, reference number used are only for convenient research. We are no way affiliate with mentioned registered trade marks and brand.
注: 关于在注册商标、机器及配件的参考编号的注解, 请见封面内页 (公司简介)

TORCH 5000



Technical data		技术参数	
Cooling 冷却方式	Water Cooled 水冷	Duty cycle 100% 暂载率100%	500Amp CO ₂ , 450Amp MIX
Wire Size 焊丝直径	Φ 0.8-1.6mm		

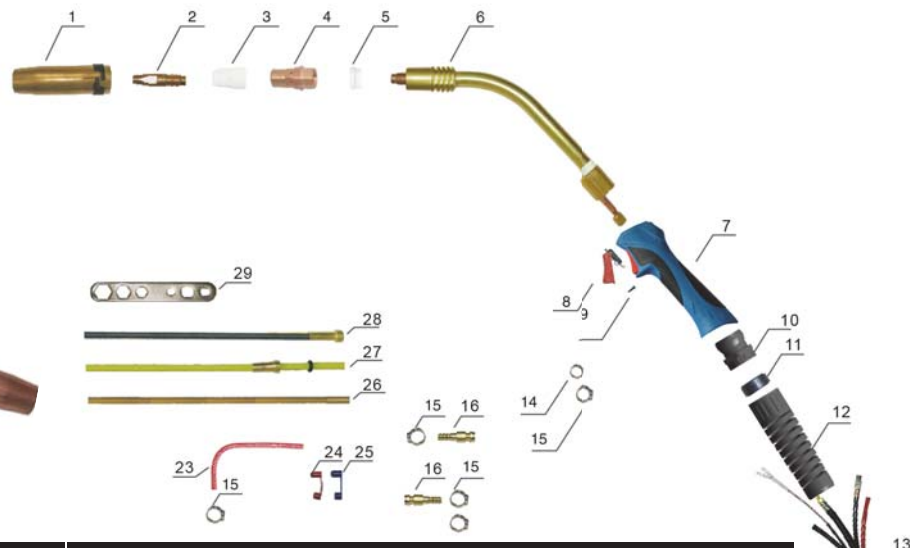

Position	Code	Ref.	Description
1	JDT0731		Gas nozzle Φ 16mm; 喷嘴 Φ 16mm
2	JDV0818-12		Contact tip Φ 1.2mm E-CU/M10x40; 导电嘴 Φ 1.2mm/M10x40mm
3	JDG0543	42.0100.1007	White ceramic gas diffuser; 白色陶瓷分流器
4	JDG0014	42.0001.5122	Gas Diffuser; 分流器
5	JAI1246	42.0100.1016	Insulator ring; 绝缘环 5000
6	JDJ0064		Torch head 5000; 枪头 5000
7	JDW0801-01		MIG handle Blue/Grip; MIG手柄/蓝色
8	JIR0081	185.0031	Trigger; 焊枪用开关
9	JGU0885		Screw M3x10; 螺丝 M3x10
10	JIK0032		Joint for MIG handle; MIG手柄用球头
11-1	JIK0863		HOUSING RING/BIG/INSIDE; 锁紧内环/大
11-2	JIK0866		HOUSING FOR PLASMA BACK BOX/BIG; 等离子后把套用锁紧环/大
12	JGU0833		Spring for cable support; 电缆支撑弹簧
13	JDE0078		Cable assembly 3m 401D-501D; 水冷电缆组 3m/401D-501D
14	JGU0733		Clamp Φ 9.5; 卡箍 Φ 9.0
15	JGU0741		Clamp Φ 8.7; 卡箍 Φ 8.0
16	JAU0801	501.0114	Quick connector water Φ 6mm; 水冷快速插头 Φ 6mm
17	JIK0775		Hose support for water cooled rear box; 水冷枪后把套用水管支柱
18	JGU0074		Screw M4x6; 螺丝 M4x6
19	JIK0774		Back box for water cooled; 水冷枪后把套
20	JIK0083		Adaptor nut/Blue; 焊枪锁紧螺母/蓝色
21	JUC0068	501.2156	Euro central adaptor body/water cooling; 欧式水冷中央接头/水冷
22	JAU0082	501.0082	Liner nut; 送丝管锁紧螺母
23	JLI0616		Output water tube M5x8mm 0.8m red; EPDM 编织管 M5x8mm 0.8m/红色
24	JIK0317		Plastic support for water cooling connector Red; 水堵/红色
25	JIK0319		Plastic support for water cooling connector Blue; 水堵/蓝色
26	JJD0237		Brass terminal Φ 3.0x4.5mm 0.35m; 铜送丝管 Φ 3.0x4.5mm/0.35m
27	JJD0221	126.0039	Teflon liner Φ 3.0x4.5mm 3m Yellow; 特氟龙管 Φ 3.0x4.5mm/3m/黄色
28	JJD0591	122.0056	Steel liner Φ 1.2-1.6mm 3m; 钢送丝管 Φ 1.2-1.6mm/3m
29	JDH6011		Spanner for MIG torches; MIG 焊枪扳手
Complete Torch			
	JDI2349-36		MIG 5000 torch 3m euro adaptor/spring pins; 焊枪5000/3m/弹性针
	JDI2340-36		MIG 5000 torch 4m euro adaptor/spring pins; 焊枪5000/4m/弹性针
	JDI2346-36		MIG 5000 torch 5m euro adaptor/spring pins; 焊枪5000/5m/弹性针



Note: About the registered trade mark, reference number used are only for convenient research. We are no way affiliate with mentioned registered trade marks and brand.

注: 关于在注册商标、机器及配件的参考编号的注解, 请见封面内页 (公司简介)

AUTO MIG 25

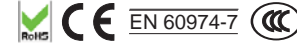

Technical data		技术参数	
Cooling 冷却方式	Gas Cooled 气冷	Duty cycle 60% 暂载率60%	230Amp CO ₂ , 200Amp MIX
Wire Size 焊丝直径	Φ 0.8-1.2mm		

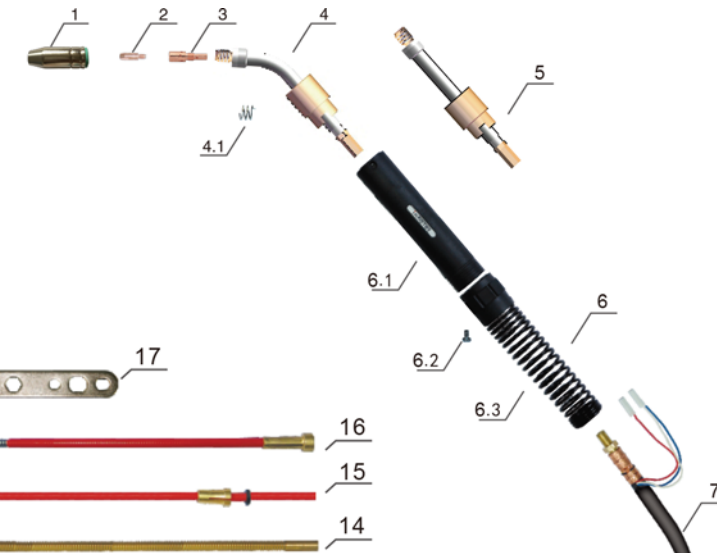

Position	Code	Ref.	Description
1	JDT0089	145.0100	Gas nozzle Φ 15mm; 喷嘴 Φ 15mm
2	JDV0015-10	140.0242	Contact tip Φ 1.0mm E-CU/M6x28; 导电嘴 Φ 1.0mm/M6x28mm
3	JDG0072	142.0001	Gas Diffuser M6x35; 分流器 M6x35 25AK
4	JDA0791		Torch head auto 25AK 45°; 自动枪头 25AK 45°
4.1	JGU0810	003.0013	spring 25AK; 弹簧 25AK
5	JDA0797		Torch head auto 25AK 0°; 自动枪头 25AK 0°
6	JDW0682		Handle for auto MIG torch; 手柄套件MIG自动枪头用
6.1	JDW0686		Handle for auto MIG torch; 手柄MIG自动枪头用
6.2	JGU0070		Screw M4x8; 螺丝 M4x8
6.3	JGU0809		Spring for cable support; 电缆支撑弹簧
7	JDO0675		Coaxial cable 3m; 同轴电缆组/3m
8	JGU0808		Spring for cable support; 电缆支撑弹簧
9	JIK0656		Back box; 后把套
10	JGU0074		Screw M4x6; 螺丝 M4x6
11	JIK0081		Adaptor nut/Blue; 焊枪锁紧螺母
12	JUC0060	501.2155	Euro central adaptor body/air cooling; 欧式中央接头/空冷
13	JAU0082	501.0082	Liner nut; 送丝管锁紧螺母
14	JJD0231		Brass terminal Φ 2.0x4.0mm 0.35m; 铜送丝管 Φ 2.0x4.0mm/0.35m
15	JJD0171	126.0021	Teflon liner Φ 2.0x4.0mm 3m Red; 特氟龙管 Φ 2.0x4.0mm/3m/红色
16	JJD0571	124.0026	Red liner Φ 1.0-1.2mm 3m; 带绝缘层送丝管 Φ 1.0-1.2mm/3m/红色
17	JDH6011		Spanner for MIG torches; MIG 焊枪扳手
Complete Torch			
	JDU0526		Torch auto MIG25AK 0° 3m euro adaptor/spring pins; 自动焊枪25AK/0°/3m/弹性针
	JDU0528		Torch auto MIG25AK 45° 3m euro adaptor/spring pins; 自动焊枪25AK/45°/3m/弹性针

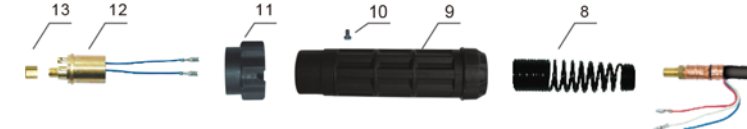

Note: About the registered trade mark, reference number used are only for convenient research. We are no way affiliate with mentioned registered trade marks and brand.

注: 关于在注册商标、机器及配件的参考编号的注解, 请见封面内页 (公司简介)

AUTO MIG 36



Technical data	技术参数
Cooling 冷却方式	Gas Cooled 气冷
Duty cycle 60% 负载率60%	300Amp CO ₂ , 270Amp MIX
Wire Size 焊丝直径	Φ 0.8-1.6mm

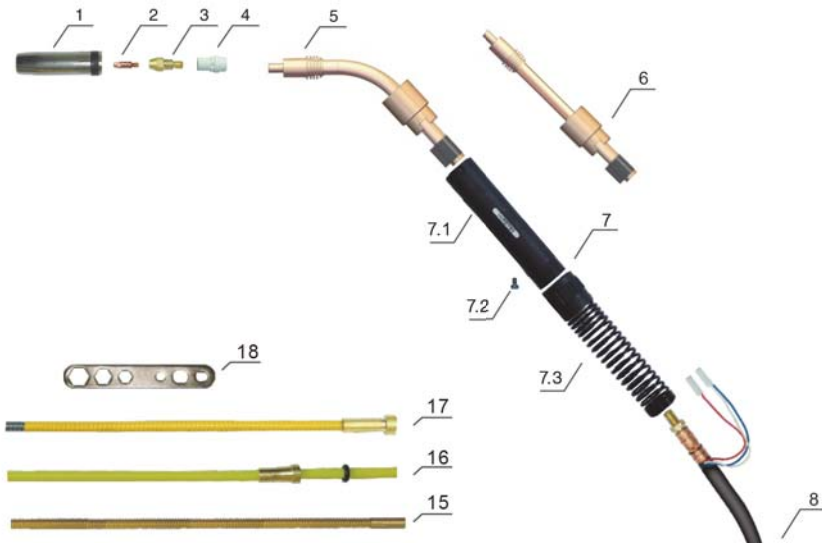

Position	Code	Ref.	Description
1	JDT0083	145.0078	Gas nozzle Φ 16mm; 喷嘴 Φ 16mm 36KD
2	JDV0015-12	140.0379	Contact tip Φ 1.2mm E-CU/M6x28; 导电嘴 Φ 1.2mm/M6x28mm
3	JDV0697	142.0011	Contact tip holder M6x32mm; 导电嘴座 36KD/M6x32mm
4	JDG0573	014.0023	White ceramic gas diffuser; 白色陶瓷分流器 36KD
5	JDA0033		Torch head auto 36KD 45°; 自动枪头 36KD 45°
6	JDA0034		Torch head auto 36KD 0°; 自动枪头 36KD 0°
7	JDW0682		Handle for auto MIG torch; MIG自动枪颈用手柄套件
7.1	JDW0686		Handle for auto MIG torch; 手柄MIG自动枪颈用
7.2	JGU0070		Screw M4x8; 螺丝 M4x8
7.3	JGU0809		Spring for cable support; 电缆支撑弹簧
8	JDO0681	160.0364	Coaxial cable 3m; 同轴电缆组/3m
9	JGU0808		Spring for cable support; 电缆支撑弹簧
10	JIK0656		Back box; 后把套
11	JGU0074		Screw M4x6; 螺丝 M4x6
12	JIK0081		Adaptor nut/Blue; 焊枪锁紧螺母
13	JUC0060	501.2155	Euro central adaptor body/air cooling; 欧式中央接头/空冷
14	JAU0082	501.0082	Liner nut; 送丝管锁紧螺母
15	JJD0237		Brass terminal Φ 3.0x4.5mm 0.35m; 铜送丝管 Φ 3.0x4.5mm/0.35m
16	JJD0221	126.0039	Teflon liner Φ 3.0x4.5mm 3m Yellow; 特氟龙管 Φ 3.0x4.5mm/3m/黄色
17	JJD0501	124.0041	Yellow liner Φ 1.2-1.6mm 3m; 带绝缘层送丝管 Φ 1.2-1.6mm/3m/黄色
18	JDH6011		Spanner for MIG torches; MIG 焊枪扳手
Complete Torch			
	JDU0533		Torch auto MIG 36KD 0° 3m euro adaptor/spring pins; 自动焊枪 36KD/0°/3m/弹性针
	JDU0530		Torch auto MIG 36KD 45° 3m euro adaptor/spring pins; 自动焊枪 36KD/45°/3m/弹性针



Note: About the registered trade mark, reference number used are only for convenient research. We are no way affiliate with mentioned registered trade marks and brand.
注: 关于在注册商标、机器及配件的参考编号的注解, 请见封面内页 (公司简介)

AUTO MIG 240



Technical data	技术参数
Cooling 冷却方式	Water Cooled 水冷
Duty cycle 100% 负载率100%	300Amp CO ₂ , 270Amp MIX
Wire Size 焊丝直径	Φ 0.8-1.2mm

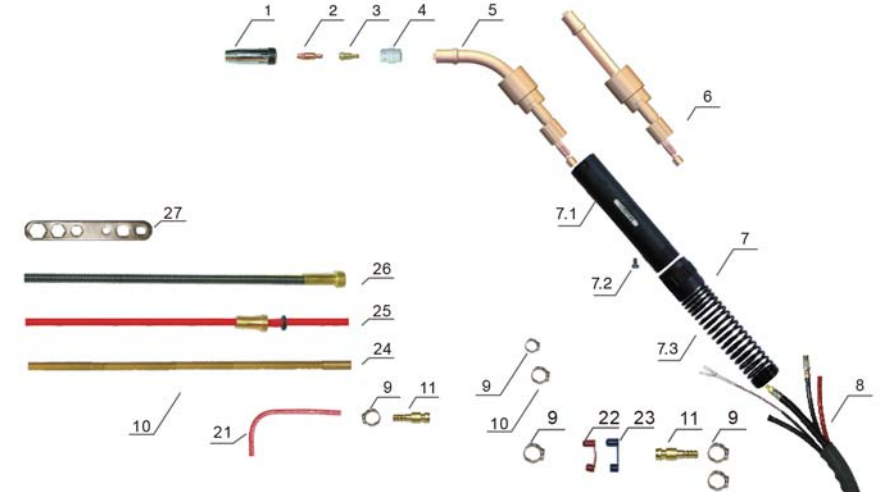

Position	Code	Ref.	Description
1	JDT0817	145.0080	Gas nozzle Φ 12.5mm; 喷嘴 Φ 12.5mm
2	JDV0014-10	140.0253	Contact tip Φ 1.0mm E-CU/M6x25; 导电嘴 Φ 1.0mm/M6x25mm
3	JDV0694	142.0003	Contact tip holder M6x26mm; 导电嘴座 24KD/M6x26mm
4	JDG0540		White ceramic gas diffuser; 白色陶瓷分流器 24KD
5	JDJ0047		Torch Head auto 240 45°; 自动枪头 240 45°
6	JDJ0048		Torch head auto 240 0°; 自动枪头 240 0°
7	JDW0682		Spring cable support for torch auto; 自动枪用电缆支撑用弹簧
7.1	JDW0686		Handle for auto MIG torch; 手柄MIG自动枪颈用
7.2	JGU0070		Screw M4x8; 螺丝 M4x8
7.3	JGU0809		Spring for cable support; 电缆支撑弹簧
8	JDE0078		Cable assembly 3m 401D-501D; 水冷电缆组 3m 401D-501D
9	JGU0745	171.0002	Clamp Φ 8.7; 卡箍 Φ 8.7
10	JGU0748	173.0001	Clamp Φ 9.5; 卡箍 Φ 9.5
11	JAU0801	501.0114	Quick connector water Φ 6; 水冷快速插头 Φ 6mm
12	JGU0881		Spring cable support 401D-501D; 电缆支撑用弹簧 401D-501D
13	JIK0788		Joint for MIG handle; MIG 手柄用球头
14	JIK0726		Handle closing ring; 手柄锁紧环
15	JIK0775		Hose support for water cooled rear box; 水冷枪后把套用水管支柱
16	JGU0074		Screw M4x6; 螺丝 M4x6
17	JIK0774		Back box for water cooled; 水冷枪后把套
18	JIK0083		Adaptor nut/Blue; 焊枪锁紧螺母/蓝色
19	JUC0068	501.2156	Euro central adaptor body/water cooling; 欧式水冷中央接头/水冷
20	JAU0082	501.0082	Liner nut; 送丝管锁紧螺母
21	JLI0616		Output water tube M5x8mm 0.8m red; EPDM 编织管 M5x8mm 0.8m/红色
22	JIK0317		Plastic support for water cooling connector /red; 水堵/红色
23	JIK0319		Plastic support for water cooling connector /blue; 水堵/蓝色
24	JJD0231		Brass terminal Φ 2.0x4.0mm 0.35m; 铜送丝管 Φ 2.0x4.0mm/0.35m
25	JJD0171	126.0005	Teflon liner Φ 2.0x4.0mm 3m Red; 特氟龙管 Φ 2.0x4.0mm/3m/红色
26	JJD0582	122.0031	Steel liner Φ 1.0-1.2mm 3m; 钢送丝管 Φ 1.0-1.2mm/3m
27	JDH6011		Spanner for MIG torches; MIG 焊枪扳手
Complete Torch			
	JDI0180		Torch auto MIG 240 0° 3m euro adaptor/spring pins; 自动焊枪 240 0°/3m/弹性针
	JDI0187		Torch auto MIG 240 45° 3m euro adaptor/spring pins; 自动焊枪 240 45°/3m/弹性针



Note: About the registered trade mark, reference number used are only for convenient research. We are no way affiliate with mentioned registered trade marks and brand.
注: 关于在注册商标、机器及配件的参考编号的注解, 请见封面内页 (公司简介)

AUTO MIG 500



Technical data	技术参数
Cooling 冷却方式	Water Cooled 水冷
Duty cycle 100% 暂载率100%	500Amp CO ₂ , 450Amp MIX
Wire Size 焊丝直径	Φ1.0-1.6mm

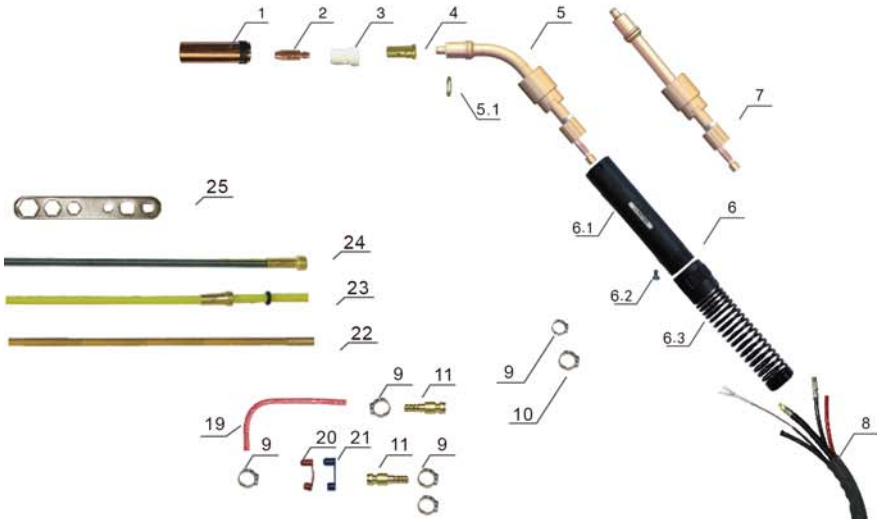

Position	Code	Ref.	Description
1	JDT0724	145.0085	Gas nozzle Φ 16mm; 喷嘴 Φ16mm 401D-501D
2	JDV0016-12	140.0442	Contact tip Φ 1.2mmE-CU/M8x30; 导电嘴 Φ 1.2mm/M8x30mm
3	JDG0535	030.0190	White ceramic gas diffuser; 白色陶瓷分流器 401D-501D
4	JDG0032	142.0022	Contact tip holder M8x25mm; 导电嘴座 M8x25mm 401D-501D
5	JDJ0027		Torch Head auto 501D 45°; 自动枪颈 501D 45°
5.1	JAI6734	030.0019	Insulator 401D-501D; 绝缘垫片 401D-501D
6	JDW0682		Handle for auto MIG torch; MIG自动枪颈用手柄
6.1	JDW0686		Handle for auto MIG torch; 手柄MIG自动枪颈用
6.2	JGU0070		Screw M4x8; 螺丝 M4x8
6.3	JGU0809		Spring for cable support; 电缆支撑弹簧
7	JDJ0028		Torch Head auto 501D 0°; 自动枪颈 501D 0°
8	JDE0078		Cable assenbly 3m 401D-501D; 水冷电缆组 3m 401D-501D
9	JGU0741		Clamp Φ 8.7; 卡箍 Φ 8.0
10	JGU0733		Clamp Φ 9.5; 卡箍 Φ 9.0
11	JAU0801	501.0114	Quick connector water Φ 6mm; 水冷快速插头 Φ 6mm
12	JGU0881		Spring cable support 401D-501D; 电缆支撑用弹簧 401D-501D
13	JIK0788		Joint for MIG handle; MIG 手柄用球头
14	JGU0074		Screw M4x6; 螺丝 M4x6
15	JIK0783		Back box for water cooled; 水冷枪后把套
16	JIK0081		Adaptor nut; 焊枪锁紧螺母
17	JUC0068	501.2156	Euro central adaptor body/water cooling; 欧式水冷中央接头/水冷
18	JAU0082	501.0082	Liner nut; 送丝管锁紧螺母
19	JLI0616		Output water tube M5x8mm 0.8m red; EPDM 编织管 M5x8mm 0.8m
20	JIK0317		Plastic support for water cooling connector / red; 水堵/红色
21	JIK0319		Plastic support for water cooling connector/ blue; 水堵/蓝色 /红色
22	JJD0237		Brass terminal Φ 3.0x4.5mm 0.35m; 铜送丝管 Φ 3.0x4.5mm/0.35m
23	JJD0221	126.0039	Teflon liner Φ 3.0x4.5mm 3m Yellow; 特氟龙管 Φ 3.0x4.5mm/3m/黄色
24	JJD0591	122.0056	Steel liner Φ 1.2-1.6mm 3m; 钢送丝管 Φ 1.2-1.6mm/3m
25	JDH6011		Spanner for MIG torches; MIG 焊枪扳手
Complete Torch	JDI0526		Torch auto MIG501D 0°3m euro adaptor/spring pins; 自动焊枪501D 0°/3m/弹性针
	JDI0522		Torch auto MIG501D 0°4m euro adaptor/spring pins; 自动焊枪501D 0°/4m/弹性针
	JDI0523		Torch auto MIG501D 0°5m euro adaptor/spring pins; 自动焊枪501D 0°/5m/弹性针
	JDI0528		Torch auto MIG501D 45°3m euro adaptor/spring pins; 自动焊枪501D 45°/3m/弹性针
	JDI0529		Torch auto MIG501D 45°4m euro adaptor/spring pins; 自动焊枪501D 45°/4m/弹性针
	JDI0520		Torch auto MIG501D 45°5m euro adaptor/spring pins; 自动焊枪501D 45°/5m/弹性针



Note: About the registered trade mark, reference number used are only for convenient research. We are no way affiliate with mentioned registered trade marks and brand.

注: 关于在注册商标、机器及配件的参考编号的注解, 请见封面内页 (公司简介)

BND 300/350



Technical data	技术参数
Cooling 冷却方式	Gas Cooled 空冷
Duty cycle 60% 暂载率60%	300/350Amp CO ₂ , 250/300Amp MIX
Wire Size 焊丝直径	Φ0.6-1.6mm

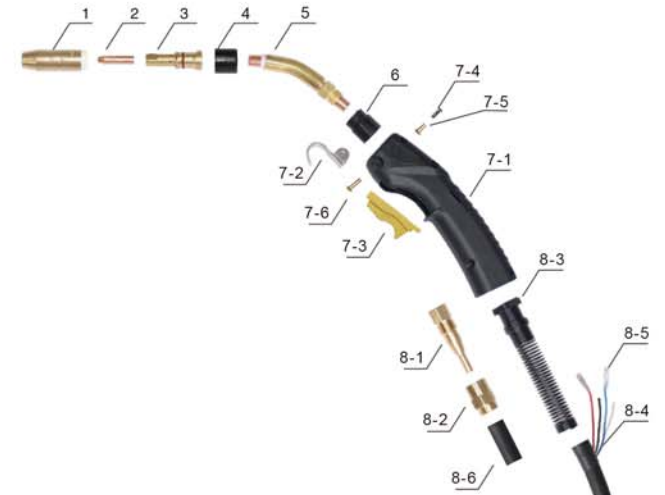

Position	Code	Ref.	Description
1	JDT0976	4392	NOZZLE D.12,5 BRASS BD 4392; 喷嘴 D.12,5 黄铜 BD4392
2	JDV0776-16	7491	CONTACT TIP D.1,6 BD SERIE 74; 导电嘴 D.1,6 BD 74系列
3	JDG0671	4335	DIFFUSER BD 4335; 分流器 BD 4335
4	JIK0056	4323R	INSULATOR TORCHBODY BERNARD; 枪颈绝缘圈 BERNARD
5	JDA0726	QT2-45	TORCHHEAD/QT2/45DEGREE; 枪颈/QT2/45度
6	JIK0047	4780	NECK INSULATOR 4780; 枪颈绝缘套 4780
7-1	JDW0064		HANDLE/BLACK/BND; 手柄/黑色/BND
7-2	JGU0983		HOOK/BND; 挂钩/BND
7-3	JIR0020	5662	TRIGGER FOR BND/5662/YELLOW; BND枪用开关/5662/黄色
7-4	JGU0627		SCRWE M3.5x0.6-10; 螺丝 M3.5x0.6-10
7-5	JGU0667		NUT M3.5x0.6-11 CH6.3/NICKEL PLATING; 镀镍螺母 M3.5x0.6-11 CH6.3
7-6	JGU0661-01		NUT M3.5x0.6-15 CH6.3/NICKEL PLATING; 镀镍螺母 M3.5x0.6-15 CH6.3
8	JDO0137		COAXIAL CABLE 4.6M/4WIRES; 同轴电缆组/4.6米/4芯控制线
8-1	JUZ6711	4213B	Back Fitting Cable BD4213B; 电缆接头 BD4213B
8-2	JGU0941		MUT/BND; 螺母/BND
8-3	JGU0840		CABLE SUPPOR SPRING/BERNARD300-400; 电缆支撑用弹簧/BERNARD300-400
8-4	JIR0711		Female Trigger Wire Connector; 开关控制线接插件(母)
8-5	JIR0719		INSULATOR FOR CONNECTOR; 接插件(母)用塑料绝缘套管
8-6	JDL0887		Heat shrink tubing; 热缩管 Φ25mm/米
8-7	JDO0387		COAXIAL CABLE 4.6M/4WIRES; 同轴电缆/4.6米/4芯控制线
8-8	JIR0001		INSULATOR TUBE/Φ3 M; 黄蜡管/Φ30mm/米
8-9	JIR0751		Preinsulated Male Cylindrical Plug; 圆柱状控制线接插件(公)
8-10	JAI0875		Joint With Spring; 带弹簧球节
8-11	JTH0988		Rings For Cable Clamping D19,3X21,3X42; 电缆压接用铜圈 D19,3X21,3X42
8-12	JUZ0601		BACK FITTING CABLE/BND; 电缆接头/BND
8-13	JGU0740		Clamp Φ11,5mm; 卡箍 Φ11.5mm
8-14	JGU0731		Clamp Φ20mm; 卡箍 Φ20mm
9	JIK0724		BACK BOX FOR AIR COOLING; 空冷枪后把套
10	JGU0074		SCREW M4X6 UNI 6107; 螺丝 M4X6 UNI 6107
11	JIK0089		Gun Plug Nut/BINZEL TYPE/BRASS SCREW; 焊枪锁紧螺母/BINZEL式/铜螺母
12	JUC0046		ASSEMBLY OF EURO CENTRE ADAPTOR/BND; 欧式中央接头组件/BND
13	JIR0061		INSULATOR TUBE/Φ5 M; 黄蜡管/Φ5 米
14	JJD0006	44215	Liner 4,5 m - 1,2-1,6 mm.(44215); 钢送丝管 4,5 m - 1,2-1,6 mm(44215)
Complete Torch	JDU5781		TORCH BND300-350/3.6M/EURO ADAPTOR; 焊枪 BND300-350/3.6M/欧式接口
	JDU5787		TORCH BND300-350/4.6M/EURO ADAPTOR; 焊枪 BND300-350/4.6M/欧式接口



Note: About the registered trade mark, reference number used are only for convenient research. We are no way affiliate with mentioned registered trade marks and brand.

注: 关于在注册商标、机器及配件的参考编号的注解, 请见封面内页 (公司简介)

BND 400



Technical data	技术参数
Cooling 冷却方式	Gas Cooled 空冷
Duty cycle 60% 暂载率60%	400Amp CO ₂ , 350Amp MIX
Wire Size 焊丝直径	Φ 0.9-1.6mm

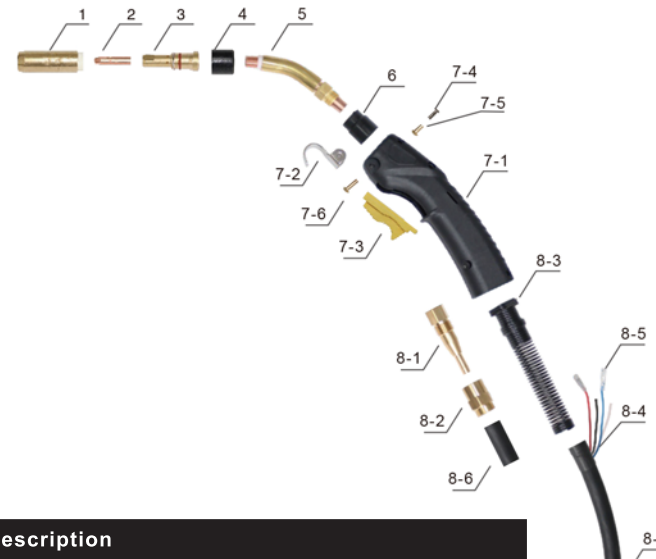

Position	Code	Ref.	Description
1	JDT0981	4491	NOZZLE D.19 BRASS BD4491;喷嘴 D.19 黄铜 BD4491
2	JDV0770-16	1591	CONTACT TIP D.1,6 BD SERIE 74;导电嘴 D.1,6 BD 15系列
3	JDG0678	4635	DIFFUSER GASBD 4635;分流器 BD 4635
4	JIK0053	4423	NOZZLE INSULATOR/BERNARD/4423;喷嘴绝缘件/BERNARD/4423
5	JDA0721	4790	TORCHHEAD/4790;枪颈/BND400/4790
6	JIK0047	4780	NECK INSULATOR 4780;枪颈绝缘套 4780
7-1	JDW0064		HANDLE/BLACK/BND;手柄/黑色/BND
7-2	JGU0983		HOOK/BND;挂钩/BND
7-3	JIR0020	5662	TRIGGER FOR BND/5662/YELLOW;BND枪用开关/5662/黄色
7-4	JGU0627		SCRWE M3.5x0.6-10;螺丝 M3.5x0.6-10
7-5	JGU0667		NUT M3.5x0.6-11 CH6.3/NICKEL PLATING;镀镍螺母 M3.5x0.6-11 CH6.3
7-6	JGU0661-01		NUT M3.5x0.6-15 CH6.3/NICKEL PLATING;镀镍螺母 M3.5x0.6-15 CH6.3
8	JDO0147		COAXIAL CABLE 4.6M/4WIRES;同轴电缆组/4.6米/4芯控制线
8-1	JUZ6711	4213B	Back Fitting Cable BD4213B;电缆接头 BD4213B
8-2	JGU0948		MUT/BND;螺母/BND
8-3	JGU0840		CABLE SUPPOR SPRING/BERNARD300-400;电缆支撑用弹簧/BERNARD300-400
8-4	JIR0711		Female Trigger Wire Connector;开关控制线接插件(母)
8-5	JIR0719		INSULATOR FOR CONNECTOR;接插件(母)用塑料绝缘套管
8-6	JDL0887		Heat shrink tubing : 热缩管Φ25mm/米
8-7	JDO0967		COAXIAL CABLE 4.6M/4WIRES;同轴电缆/4.6米/4芯控制线
8-8	JIR0001		INSULATOR TUBE/Φ3 M;黄蜡管/Φ30mm/米
8-9	JIR0751		Preinsulated Male Cylindrical Plug;圆柱状控制线接插件(公)
8-10	JAI0875		Joint With Spring;带弹簧球节
8-11	JTH0988		Rings For Cable Clamping D19,3X21,3X42;电缆压接用铜圈 D19,3X21,3X42
8-12	JUZ0601		BACK FITTING CABLE/BND;电缆接头/BND
8-13	JGU0740		Clamp Φ11,5mm;卡箍 Φ11.5mm
8-14	JGU0731		Clamp Φ20mm;卡箍 Φ20mm
9	JIK0724		BACK BOX FOR AIR COOLING;空冷枪后把套
10	JGU0074		SCREW M4X6 UNI 6107;螺丝 M4X6 UNI 6107
11	JIK0089		Gun Plug Nut/BINZEL TYPE/BRASS SCREW;焊枪锁紧螺母/BINZEL式/铜螺母
12	JUC0046		ASSEMBLY OF EURO CENTRE ADAPTOR/BND;欧式中央插头组件/BND
13	JIR0061		INSULATOR TUBE/Φ5 M;黄蜡管/Φ5 米
14	JJD0006	44215	Liner 4,5 m - 1,2-1,6 mm.(44215);钢送丝管 4,5 m - 1,2-1,6 mm(44215)
Complete Torch	JDU5791		TORCH BND400/3.6M/EURO ADAPTOR;焊枪 BND400/3.6M/欧式接口
	JDU5797		TORCH BND400/4.6M/EURO ADAPTOR;焊枪 BND400/4.6M/欧式接口



Note: About the registered trade mark, reference number used are only for convenient research. We are no way affiliate with mentioned registered trade marks and brand.
注:关于在注册商标、机器及配件的参考编号的注解,请见封面内页(公司简介)

BND 300/350



Technical data	技术参数
Cooling 冷却方式	Gas Cooled 空冷
Duty cycle 60% 暂载率60%	300/350Amp CO ₂ , 250/300Amp MIX
Wire Size 焊丝直径	Φ 0.6-1.6mm

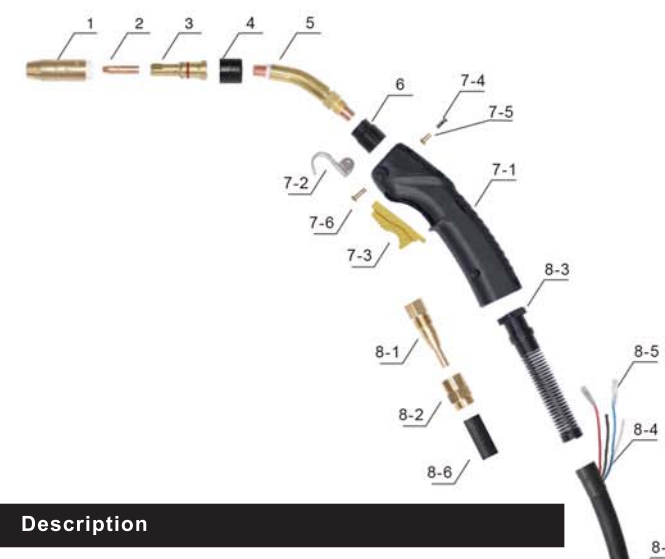

Position	Code	Ref.	Description
1	JDT0976	4392	NOZZLE D.12,5 BRASS BD 4392;喷嘴 D.12,5 黄铜 BD4392
2	JDV0776-16	7491	CONTACT TIP D.1,6 BD SERIE 74;导电嘴 D.1,6 BD 74系列
3	JDG0671	4335	DIFFUSER BD 4335;分流器 BD 4335
4	JIK0056	4323R	INSULATOR TORCHBODY BERNARD;枪颈绝缘圈 BERNARD
5	JDA0726	QT2-45	TORCHHEAD/QT2/45DEGREE; 枪颈/QT2/45度
6	JIK0047	4780	NECK INSULATOR 4780;枪颈绝缘套 4780
7-1	JDW0064		HANDLE/BLACK/BND;手柄/黑色/BND
7-2	JGU0983		HOOK/BND;挂钩/BND
7-3	JIR0020	5662	TRIGGER FOR BND/5662/YELLOW;BND枪用开关/5662/黄色
7-4	JGU0627		SCRWE M3.5x0.6-10;螺丝 M3.5x0.6-10
7-5	JGU0667		NUT M3.5x0.6-11 CH6.3/NICKEL PLATING;镀镍螺母 M3.5x0.6-11 CH6.3
7-6	JGU0661-01		NUT M3.5x0.6-15 CH6.3/NICKEL PLATING;镀镍螺母 M3.5x0.6-15 CH6.3
8	JDO0137		COAXIAL CABLE 4.6M/4WIRES;同轴电缆组/4.6米/4芯控制线
8-1	JUZ6711	4213B	Back Fitting Cable BD4213B;电缆接头 BD4213B
8-2	JGU0941		MUT/BND;螺母/BND
8-3	JGU0840		CABLE SUPPOR SPRING/BERNARD300-400;电缆支撑用弹簧/BERNARD300-400
8-4	JIR0711		Female Trigger Wire Connector;开关控制线接插件(母)
8-5	JIR0719		INSULATOR FOR CONNECTOR;接插件(母)用塑料绝缘套管
8-6	JDL0887		Heat shrink tubing : 热缩管Φ25mm/米
8-7	JDO0387		COAXIAL CABLE 4.6M/4WIRES;同轴电缆/4.6米/4芯控制线
8-8	JIR0001		INSULATOR TUBE/Φ3 M;黄蜡管/Φ30mm/米
8-9	JIR0751		Preinsulated Male Cylindrical Plug;圆柱状控制线接插件(公)
8-10	JAI0875		Joint With Spring;带弹簧球节
8-11	JTH0988		Rings For Cable Clamping D19,3X21,3X42;电缆压接用铜圈 D19,3X21,3X42
8-12	JUZ0601		BACK FITTING CABLE/BND;电缆接头/BND
8-13	JGU0740		Clamp Φ11,5mm;卡箍 Φ11.5mm
8-14	JGU0731		Clamp Φ20mm;卡箍 Φ20mm
9	JIK0724		BACK BOX FOR AIR COOLING;空冷枪后把套
10	JGU0074		SCREW M4X6 UNI 6107;螺丝 M4X6 UNI 6107
11	JIK0089		Gun Plug Nut/BINZEL TYPE/BRASS SCREW;焊枪锁紧螺母/BINZEL式/铜螺母
12	JUC0046		ASSEMBLY OF EURO CENTRE ADAPTOR/BND;欧式中央插头组件/BND
13	JIR0061		INSULATOR TUBE/Φ5 M;黄蜡管/Φ5 米
14	JJD0006	44215	Liner 4,5 m - 1,2-1,6 mm.(44215);钢送丝管 4,5 m - 1,2-1,6 mm(44215)
Complete Torch	JDU5781		TORCH BND300-350/3.6M/EURO ADAPTOR;焊枪 BND300-350/3.6M/欧式接口
	JDU5787		TORCH BND300-350/4.6M/EURO ADAPTOR;焊枪 BND300-350/4.6M/欧式接口



Note: About the registered trade mark, reference number of the model of the machine and spare parts, please see inner cover (company introduction)
注:关于在注册商标、机器及配件的参考编号的注解,请见封面内页(公司简介)

BND 400



Technical data	技术参数
Cooling 冷却方式	Gas Cooled 空冷
Duty cycle 60% 暂载率60%	400Amp CO ₂ , 350Amp MIX
Wire Size 焊丝直径	Φ0.9-1.6mm

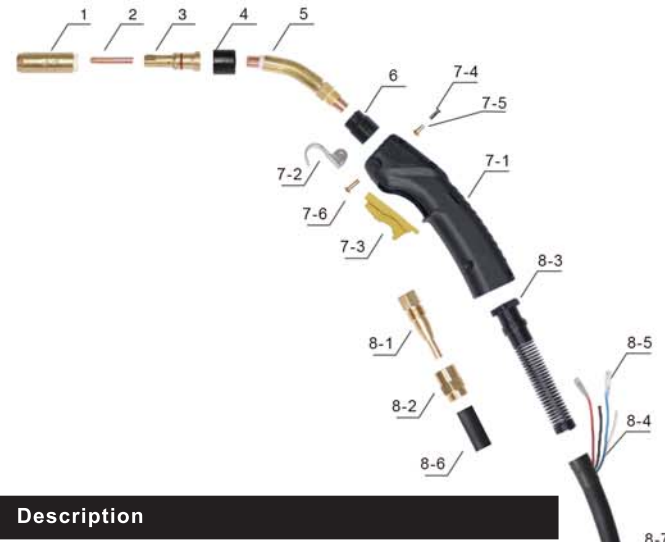

Position	Code	Ref.	Description
1	JDT0981	4491	NOZZLE D.19 BRASS BD4491;喷嘴 D. 19 黄铜 BD4491
2	JDV0770-16	1591	CONTACT TIP D.1,6 BD SERIE 74;导电嘴 D.1,6 BD 15系列
3	JDG0678	4635	DIFFUSER GASBD 4635;分流器 BD 4635
4	JIK0053	4423	NOZZLE INSULATORY/BERNARD/4423;喷嘴绝缘件/BERNARD/4423
5	JDA0721	4790	TORCHHEAD/4790;枪颈/BND400/4790
6	JIK0047	4780	NECK INSULATOR 4780;枪颈绝缘套 4780
7-1	JDW0064		HANDLE/BLACK/BND;手柄/黑色/BND
7-2	JGU0983		HOOK/BND;挂钩/BND
7-3	JIR0020	5662	TRIGGER FOR BND/5662/YELLOW;BND枪用开关/5662/黄色
7-4	JGU0627		SCRWE M3.5x0.6-10;螺丝 M3.5x0.6-10
7-5	JGU0667		NUT M3.5x0.6-11 CH6.3/NICKEL PLATING;镀镍螺母 M3.5x0.6-11 CH6.3
7-6	JGU0661-01		NUT M3.5x0.6-15 CH6.3/NICKEL PLATING;镀镍螺母 M3.5x0.6-15 CH6.3
8	JDO0147		COAXIAL CABLE 4.6M/4WIRES;同轴电缆组/4.6米/4芯控制线
8-1	JUZ6711	4213B	Back Fitting Cable BD4213B;电缆接头 BD4213B
8-2	JGU0948		MUT/BND;螺母/BND
8-3	JGU0840		CABLE SUPPOR SPRING/BERNARD300-400;电缆支撑用弹簧/BERNARD300-400
8-4	JIR0711		Female Trigger Wire Connector;开关控制线接插件(母)
8-5	JIR0719		INSULATOR FOR CONNECTOR;接插件(母)用塑料绝缘套管
8-6	JDL0887		Heat shrink tubing : 热缩管Φ25mm/米
8-7	JDO0967		COAXIAL CABLE 4.6M/4WIRES;同轴电缆/4.6米/4芯控制线
8-8	JIR0001		INSULATOR TUBE/Φ3 M;黄蜡管/Φ30mm/米
8-9	JIR0751		Preinsulated Male Cylindrical Plug;圆柱状控制线接插件(公)
8-10	JAI0875		Joint With Spring;带弹簧球节
8-11	JTH0988		Rings For Cable Clamping D19,3X21,3X42;电缆压接用铜圈 D19,3X21,3X42
8-12	JUZ0601		BACK FITTING CABLE/BND;电缆接头/BND
8-13	JGU0740		Clamp Φ11,5mm;卡箍 Φ11.5mm
8-14	JGU0731		Clamp Φ20mm;卡箍 Φ20mm
9	JIK0724		BACK BOX FOR AIR COOLING;空冷枪后把套
10	JGU0074		SCREW M4X6 UNI 6107;螺丝 M4X6 UNI 6107
11	JIK0089		Gun Plug Nut/BINZEL TYPE/BRASS SCREW;焊枪锁紧螺母/BINZEL式/铜螺母
12	JUC0046		ASSEMBLY OF EURO CENTRE ADAPTOR/BND;欧式中央插头组件/BND
13	JIR0061		INSULATOR TUBE/Φ5 M;黄蜡管/Φ5 米
14	JJD0006	44215	Liner 4,5 m - 1,2-1,6 mm.(44215);钢送丝管 4,5 m - 1,2-1,6 mm(44215)
Complete Torch	JDU5791		TORCH BND400/3.6M/EURO ADAPTOR;焊枪 BND400/3.6M/欧式接口
	JDU5797		TORCH BND400/4.6M/EURO ADAPTOR;焊枪 BND400/4.6M/欧式接口



Note: About the registered trade mark, reference number of the model of the machine and spare parts, please see inner cover (company introduction)
注:关于在注册商标、机器及配件的参考编号的注解,请见封面内页(公司简介)

TORCH P180



Technical data	技术参数
Cooling 冷却方式	Gas Cooled 气冷
Duty cycle 60% 暂载率60%	200Amp CO ₂ , 160Amp MIX
Wire Size 焊丝直径	Φ0.8-1.2mm

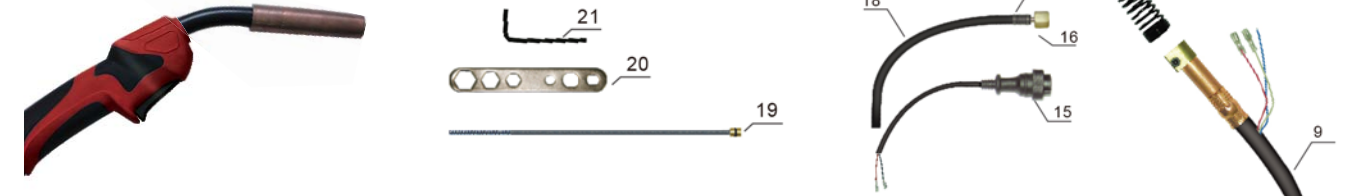

Position	Code	Ref.	Description
1	JDT0467		Nozzle PAN 180;喷嘴/日式180
2	JDV0757-10		Contact tip Φ 1.0 M6x45;导电嘴 Φ 1.0 M6x45
3	JDA0751		Torch head PAN 180;枪颈/日式180
4	JDW0806-01		MIG handle PAN180; MIG手柄/日式180
5	JIR0197		Switch for MIG/PAN; 微动开关/日式枪用
6	JGU0871		Spring for switch/PAN; 弹簧/日式枪微动开关用
7	JGU0885		Screw M3x10mm; 螺丝 M3x10mm
8	JGU0836		Spring cable support; 电缆支撑用弹簧
9	JDO0110-01		Coaxial cable assembling /3m/PAN; 同轴电缆组 /3m/日式
10	JAI0706		Gas connector for MIG torch/PAN; 日式枪后气管接头
11	JGU0832		Spring cable support/PAN; 电缆支撑用弹簧/日式
12	JGU0031		Nut M4; 六角螺母 M4
13	JGU0080		Screw M4x20; 螺丝 M4x20
14	JIK0704		Back box for PAN torch; 后把套/日式
15	JIR0760		Connector 2 holes/with connectors/PAN; 两芯航插
16	JAU9010		Connector with hexagonal nut 9/16-18; 接头带 9/16-18 六角螺母
17	JGU0814		Spring for gas tube; 气管用弹簧
18	JLI0679		EPDM tube 5x10 300mm; EPDM管 5x10 300mm
19	JJD0562		Insulated steel liner 0.8-1.0 3.1m Black PAN 180; 带绝缘层送丝管 0.8-1.0 3.1m/黑色/日式180
20	JDH6011		Spanner for MIG torches; MIG 焊枪扳手
21	JDH6018		Spanner for PAN torch; 日式枪用六角扳手
Complete Torch			
	JDU6542-36		MIG 180 torch 3m PAN; 焊枪180 3m 日式
	JDU6543-36		MIG 180 torch 4m PAN; 焊枪180 4m 日式
	JDU6544-36		MIG 180 torch 5m PAN; 焊枪180 5m 日式

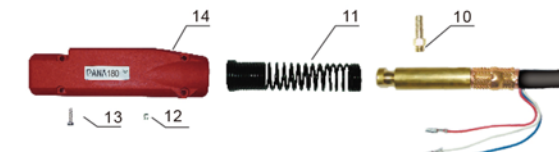

Note: About the registered trade mark, reference number of the model of the machine and spare parts, please see inner cover (company introduction)
注:关于在注册商标、机器及配件的参考编号的注解,请见封面内页(公司简介)

TORCH P350



Technical data		技术参数	
Cooling 冷却方式	Gas Cooled 气冷	Duty cycle 60% 暂载率60%	340Amp CO ₂ , 320Amp MIX
Wire Size 焊丝直径	Φ 0.8-1.6mm		

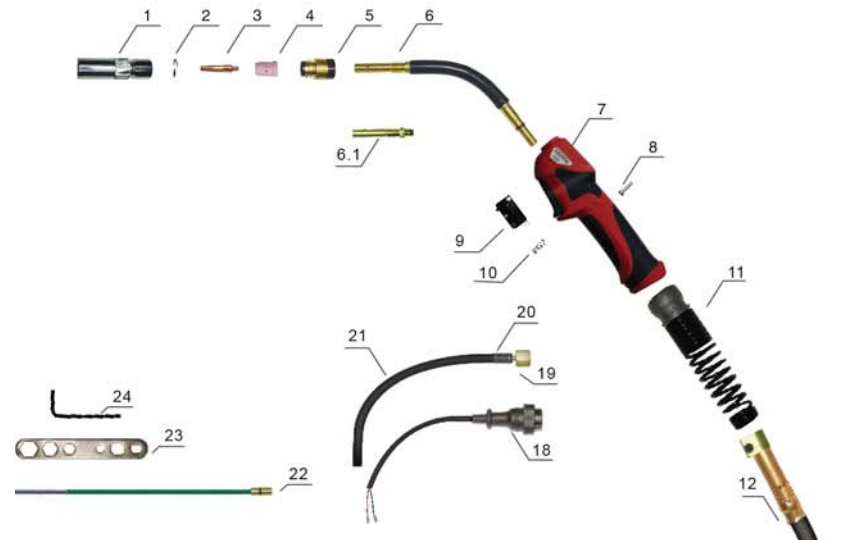

Position	Code	Ref.	Description
----------	------	------	-------------

1	JDT0407		Nozzle P350; 喷嘴 日式350
2	JGU0679		Grower M21mm; 发黑弹垫 M21mm
3	JDV0757-10		Contact tip Φ 1.0mm E-CU M6x45; 导电嘴 Φ 1.0mm E-CU M6x45mm
4	JDG0987		Ceramic diffuser P350; 陶瓷分流器 日式350
5	JDT6610		Insulator P350; 绝缘筒 日式350
6	JDA0750		Torch head P350; 枪颈 日式350
6.1	JDG0982		Torch head front part P350; 枪颈前段 日式350
7	JDW0861-01		MIG handle P350/500; MIG手柄 日式350/500
8	JGU0885		Screw M3x10mm; 螺丝 M3x10mm
9	JIR0197		Switch for MIG/PAN; 微动开关/日式枪用
10	JGU0871		Spring for switch/PAN; 弹簧/日式枪微动开关用
11	JAI0875		Joint with spring; 带弹簧球节
12	JDO0199-01		Coaxial cable 3m; 同轴电缆组/3m
13	JAI7076		Gas connector for MIG torch/PAN; 气管接头/日式
14	JGU0832		Spring cable support; 电缆支撑用弹簧/日式
15	JIK0704		Back box; 后把套/日式
16	JGU0031		Nut M4; 六角螺母 M4
17	JGU0080		Screw M4x22mm; 螺丝 M4x22mm
18	JIR0760		Connector 2 holes; 两芯航插/日式/带控制线接头
19	JAU9010		Connector with hexagonal nut 9/16-18; 接头9/16-18六角螺母
20	JGU0814		Spring for gas tube; 气管用弹簧
21	JLI0679		EPDM tube Φ 5x10mm 300mm; EPDM管 Φ 5x10mm 300mm
22	JJD0521		Green steel liner Φ 1.0-1.2mm 3m; 带绝缘层送丝管 Φ 1.0-1.2mm/3m/绿色
23	JDH6011		Spanner for MIG torches; MIG 焊枪扳手
24	JDH6018		Spanner for PAN torch; 日式枪用六角扳手
Complete Torch	JDU6241-36		MIG P350 torch 3m PAN; 焊枪350 3m 日式
	JDU6247-36		MIG P350 torch 4m PAN; 焊枪350 4m 日式
	JDU6248-36		MIG P350 torch 5m PAN; 焊枪350 5m 日式

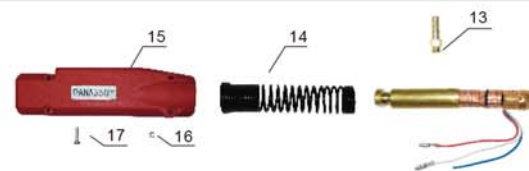

Note: About the registered trade mark, reference number of the model of the machine and spare parts, please see inner cover (company introduction)
注: 关于在注册商标、机器及配件的参考编号的注解, 请见封面内页 (公司简介)

TORCH P500



Technical data		技术参数	
Cooling 冷却方式	Gas Cooled 气冷	Duty cycle 35% 暂载率 35%	500Amp CO ₂ , 450Amp MIX
Wire Size 焊丝直径	Φ 0.8-1.6mm		

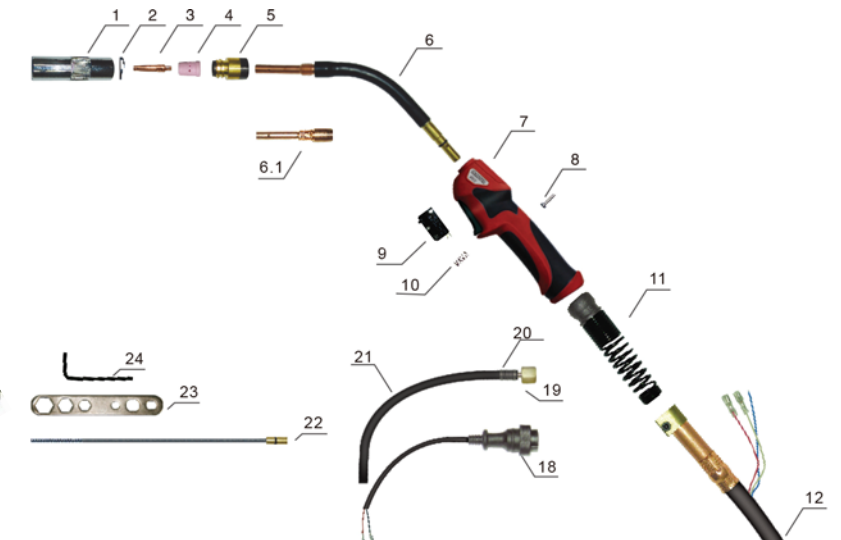

Position	Code	Ref.	Description
----------	------	------	-------------

1	JDT0468		Nozzle P500; 喷嘴/日式 500
2	JGU0670		Grower M25mm; 发黑弹垫 M25mm
3	JDV0757-12		Contact tip Φ 1.2mm E-CU/M6x45; 导电嘴 Φ 1.2mm/M6x45mm
4	JDG0989		Ceramic diffuser P500; 陶瓷分流器 日式 500
5	JDT6614		Insulator P500; 绝缘筒/日式 500
6	JDA0758		Torch head P500; 日式500 枪颈
6.1	JDG0986		Torch head front part P500; 枪颈前段 日式500
7	JDW0861-01		MIG handle P350/500; MIG手柄 日式350/500
8	JGU0885		Screw M3x10mm; 螺丝 M3x10mm
9	JIR0197		Switch for MIG/PAN; 微动开关/日式枪用
10	JGU0871		Spring for switch/PAN; 弹簧/日式枪微动开关用
11	JAI0875		Joint with spring; 带弹簧球节
12	JDO0191-01		Coaxial cable 3m; 同轴电缆组/3m
13	JAI7076		Gas connector for MIG torch/PAN; 气管接头/日式
14	JGU0832		Spring cable support; 电缆支撑用弹簧/日式
15	JIK0704		Back box; 后把套/日式
16	JGU0031		Nut M4; 六角螺母 M4
17	JGU0080		Screw M4x22mm; 螺丝 M4x22mm
18	JIR0760		Connector 2 holes; 两芯航插
19	JAU9010		Connector with hexagon nut 9/16-18; 接头9/16-18六角螺母
20	JGU0814		Spring for gas tube; 气管用弹簧
21	JLI0679		EPDM tube Φ 5x10mm 300mm; EPDM管 Φ 5x10mm 300mm
22	JJD0529		Black steel liner Φ 1.2-1.6mm 3m; 带绝缘层送丝管 Φ 1.2-1.6mm/3m/黑色
23	JDH6011	191.0001	Spanner for MIG torches; MIG 焊枪扳手
24	JDH6018		Spanner for PAN torch; 日式枪用六角扳手
Complete Torch	JDU6251-36		MIG P500 torch 3m PAN; 焊枪500 3m 日式
	JDU6257-36		MIG P500 torch 4m PAN; 焊枪500 4m 日式
	JDU6258-36		MIG P500 torch 5m PAN; 焊枪500 5m 日式

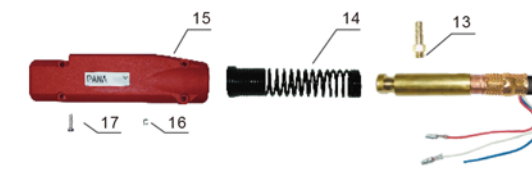

Note: About the registered trade mark, reference number of the model of the machine and spare parts, please see inner cover (company introduction)
注: 关于在注册商标、机器及配件的参考编号的注解, 请见封面内页 (公司简介)

TW-180



Technical data 技术参数	
Cooling 冷却方式	Gas Cooled 气冷
Duty cycle 60% 暂载率60%	180Amp CO ₂ , 120Amp MIX
Wire Size 焊丝直径	Φ0.6-1.2mm

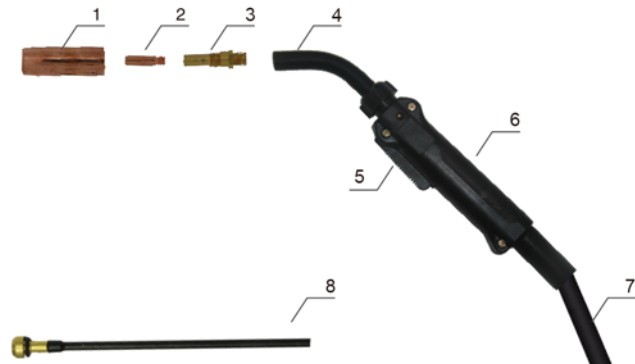

Position	Code	Ref.	Description
1	JDT0097	21-50	Gas nozzle Φ12.5; 喷嘴 Φ12.5mm
2	JDV0773-08	11-30	Contact tip 0.030'; 导电嘴 0.030'
3	JDG0074	51	Diffuser 51; 分流器 51
4	JDA0083	61-60	Conductor tube 60°; 枪颈 60°
5	JIR0073	91	Trigger switch assembly; 开关总成
6	JDW0764	81	MIG handle with screw; 手柄带螺丝
7	JDO0811		Cable assembly; 电缆组
8	JJD0077-03		Steel liner 11' 0.030"-0.035"; 钢送丝管 11' 0.030"-0.035"
Complete Torch			
	JDU5611	110-3035	TW1 Torch 3m; TW1枪 3m
	JDU5617	112-3035	Tw1 Torch 4m; TW1枪 4m
	JDU5618	115-3035	Tw1 Torch 4.6m; TW1枪 4.6m
	JDU5626	X110-4045	TW1 Torch 3m euro adaptor; TW1枪 3m 欧式中央插头
	JDU5622	X112-4045	TW1 Torch 4m euro adaptor; TW1枪 4m 欧式中央插头
	JDU5623	X115-4045	Tw1 Torch 4.6m euro adaptor; TW1枪 4.6m 欧式中央插头
	JDU5624	M110-3035	Tw1 Torch 3m Miller adaptor; TW1枪 3m 米勒后接口
	JDU5625	M112-3035	Tw1 Torch 4m Miller adaptor; TW1枪 4m 米勒后接口
	JDU5631	M115-3035	Tw1 Torch 4.6m Miller adaptor; TW1枪 4.6m 米勒后接口



Note: About the registered trade mark, reference number of the model of the machine and spare parts, please see inner cover (company introduction)
注: 关于在注册商标、机器及配件的参考编号的注解, 请见封面内页 (公司简介)

TW-200



Technical data 技术参数	
Cooling 冷却方式	Gas Cooled 气冷
Duty cycle 60% 暂载率60%	200Amp CO ₂ , 150Amp MIX
Wire Size 焊丝直径	Φ0.6-1.2mm

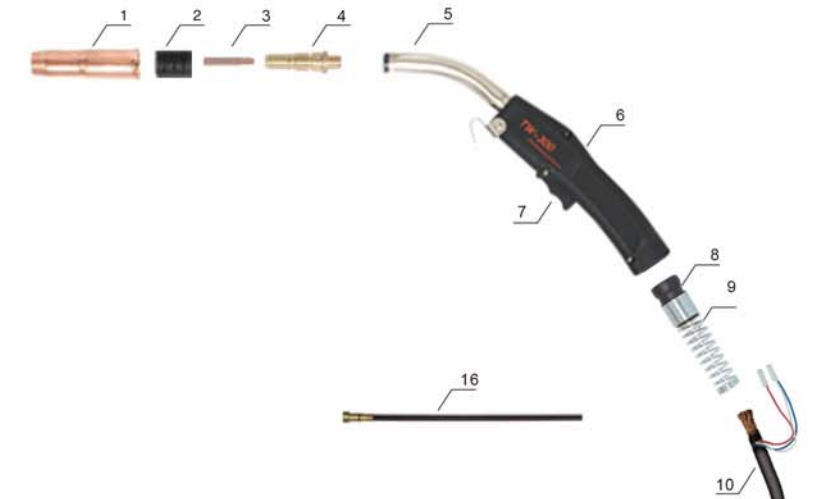

Position	Code	Ref.	Description
1	JDT0790	22-50	Gas nozzle Φ12.7; 喷嘴 Φ12.7mm
2	JDL0691	32	Insulator; 绝缘筒
3	JDV0019-09	14-35	Contact tip 0.035'; 导电嘴 0.035'
4	JDG0088	52	Diffuser; 分流器
5	JDA0602-02	62J-45	Torch head 45GR/62J-45/Nickel-Plated outer tube /With fitting 枪颈 45GR/62J-45/镀镍外管/带接头
6	JDW0703	83	MIG handle with screw; MIG手柄带螺丝
7	JIR0074	81	Trigger switch assembly; 开关套件
8	JIK0798		Joint for TW1-4; 手柄用球头/TW1-4
9	JGU0801-01		Spring for cable support/Zin/TW; 电缆支撑用弹簧/镀白锌/TW
10	JDO0709-300		Cable assembly/3M; 电缆组/3米
11	JGU0835-01		Spring for cable support/Blue and white zinc plating; 电缆支撑用弹簧/镀蓝白锌
12	JIK0607		Back box with closing ring; 后把套/含锁紧环
13	JGU0074	EA0018	Screw M4x6; 螺丝 M4x6
14	JAI7062		Continental adaptor / Miller M10X1; 欧式转换接头/米勒 M10X1
15	JUP0003		Connetcing adaptor TW1-4; 接头连杆/TW1-4
16	JJD0078-06		Steel liner 11' 0.030"-0.035"; 钢送丝管 11' 0.030"-0.035"
Complete Torch			
	JDU5711		TW2 Torch 3m; TW2枪 3m
	JDU5717		TW2 Torch 4m; TW2枪 4m
	JDU5718		Tw2 Torch 4.6m; TW2枪 4.6m
	JDU5726		TW2 Torch 3m euro adaptor; TW2枪 3m/欧式中央插头
	JDU5722		TW2 Torch 4m euro adaptor; TW2枪 4m/欧式中央插头
	JDU5723		Tw2 Torch 4.6m euro adaptor; TW2枪 4.6m/欧式中央插头
	JDU5724	M210-3035	Tw2 Torch 3m Miller adaptor; TW2枪 3m 米勒后接口
	JDU5725	M212-3035	Tw2 Torch 4m Miller adaptor; TW2枪 4m 米勒后接口
	JDU5731	M215-3035	Tw2 Torch 4.6m Miller adaptor; TW2枪 4.6m 米勒后接口



Note: About the registered trade mark, reference number of the model of the machine and spare parts, please see inner cover (company introduction)
注: 关于在注册商标、机器及配件的参考编号的注解, 请见封面内页 (公司简介)

TW-300



Technical data		技术参数	
Cooling 冷却方式	Gas Cooled 气冷		
Duty cycle 60% 暂载率60%	300Amp CO ₂ , 250Amp MIX		
Wire Size 焊丝直径	Φ0.8-1.6mm		

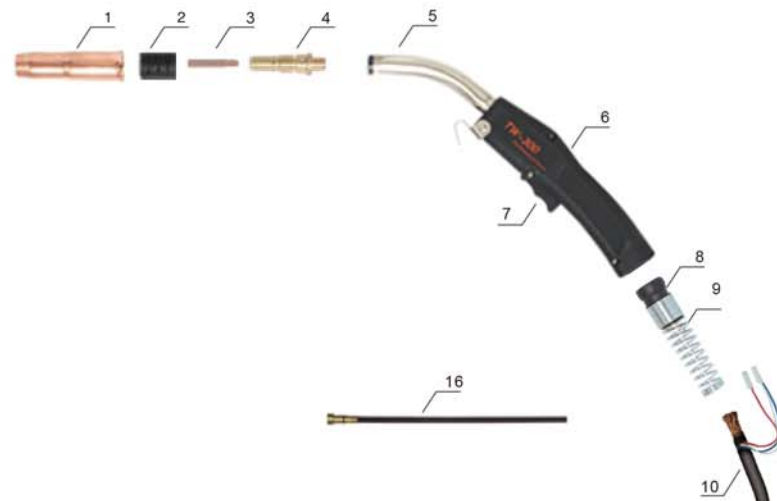

Position	Code	Ref.	Description
1	JDT0602	24A-62	Gas nozzle Φ16;喷嘴 Φ16mm
2	JDL0697	34A	Insulator;绝缘筒
3	JDV0019-12	14-45	Contact tip 0.045";导电嘴 0.045"
4	JDG0081	54A	Diffuser ;分流器
5	JDA0605-01	63J-45	Conductor tube 45°;枪颈 45°
6	JDW0703	83	MIG handle with screw;MIG手柄带螺丝
7	JIR0074		Trigger Kit;开关套件
8	JIK0798		JOINT FOR TW1-4;手柄用球头/TW1-4
9	JGU0801-01		Spring for cable support/Zin/TW;电缆支撑用弹簧/镀白锌/TW
10	JDO00911		Cable assembly/3M;电缆组/3米
11	JGU0835		Spring for cable support/Blue and white zinc plating;电缆支撑用弹簧/镀蓝白锌
12	JIK0883		Back box with closing ring;后把套/含锁紧环
13	JGU0074	EA0018	Screw M4x6;螺丝 M4x6
14	JAI7062		Continental adapter / Miller M10X1; 欧式转换接头/米勒 M10X1
15	JUP0003		Connetcing adaptor TW1-4;转接头连杆/TW1-4
16	JJD0078-06		Steel liner 11' 0.030"-0.035";钢送丝管 11' 0.030"-0.035"
Complete Torch			
	JDU5811	310-3545	TW3 Torch 3m;TW3枪 3m
	JDU5817	312-3545	TW3 Torch 4m;TW3枪 4m
	JDU5818	315-3545	Tw3 Torch 4.6m;TW3枪 4.6m
	JDU5826	X310-3545	TW3 Torch 3m euro adaptor;TW3枪 3m 欧式中央插头
	JDU5822	X312-3545	TW3 Torch 4m euro adaptor;TW3枪 4m 欧式中央插头
	JDU5823		TW3 Torch 4.6m euro adaptor;TW3枪 4.6m 欧式中央插头
	JDU5824	M310-3545	Tw3 Torch 3m Miller adaptor;TW3枪 3m 米勒后接口
	JDU5825	M312-3545	Tw3 Torch 4m Miller adaptor;TW3枪 4m 米勒后接口
	JDU5831	M315-3545	Tw3 Torch 4.6m Miller adaptor;TW3枪 4.6m 米勒后接口



Note: About the registered trade mark, reference number of the model of the machine and spare parts, please see inner cover (company introduction)
注:关于在注册商标、机器及配件的参考编号的注解, 请见封面内页(公司简介)

TW-400



Technical data		技术参数	
Cooling 冷却方式	Gas Cooled 气冷		
Duty cycle 60% 暂载率60%	400Amp CO ₂ , 350Amp MIX		
Wire Size 焊丝直径	Φ0.8-2.0mm		

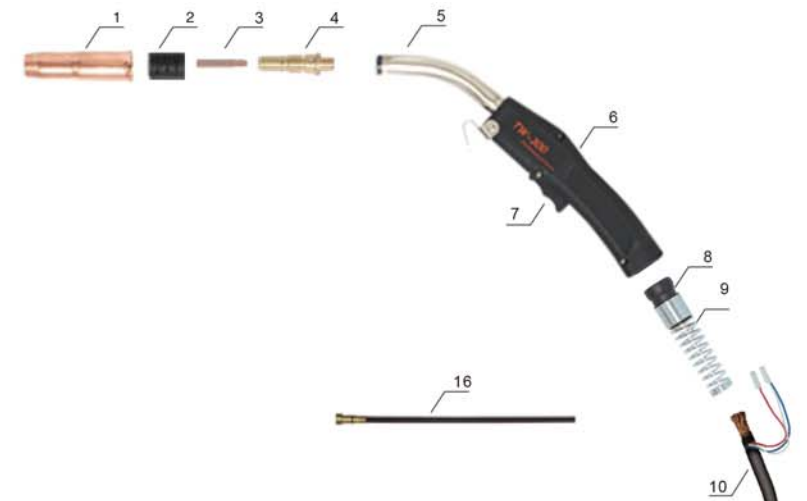

Position	Code	Ref.	Description
1	JDT0602	24A-62	Gas nozzle Φ16;喷嘴 Φ16mm
2	JDL0697	34A	Insulator ;绝缘筒
3	JDV0010-12	14-116	Contact tip 1.2/ 1/4-28X37.4;导电嘴 1.2/ 1/4-28X37.4
4	JDG0081	54A	Diffuser ;分流器
5	JDA0600-01		Torch head 60GR/TW4/64J-60/Nickel-plated outer tube;枪颈 60GR/TW4/64J-60/镀镍外管
6	JDW0704	84A	MIG handle with screw;MIG手柄带螺丝
7	JIR0092		Trigger Kit/TW;开关套件/TW
8	JIK0788		Joint for MIG handle;MIG手柄用球头
9	JGU0887-02		Spring for cable support/Zin/Long/TW;电缆支撑用弹簧/镀白锌/加长/TW
10	JDO0919		Cable assembly/3M;电缆组/3米
11	JGU0835		Spring for cable support/Blue and white zinc plating;电缆支撑用弹簧/镀蓝白锌
12	JIK0883		Back box with closing ring;后把套/含锁紧环
13	JGU0074	EA0018	Screw M4x6;螺丝 M4x6
14	JAI7062		Continental adapter / Miller M10X1; 欧式转换接头/米勒 M10X1
15	JUP0003		Connetcing adaptor TW1-4;转接头连杆/TW1-4
16	JJD0010-03		Steel liner 3.4M 0.9-1.2/TW;钢送丝管 3.4米 0.9-1.2/TW
Complete Torch			
	JDU5911	410-3545	TW4 Torch 3m;TW4枪 3m
	JDU5917	412-3545	TW4 Torch 4m;TW4枪 4m
	JDU5918	415-3545	TW4 Torch 4.6m;TW4枪 4.6m
	JDU5926	X410-3545	TW4 Torch 3m euro adaptor;TW4枪 3m 欧式中央插头
	JDU5922	X412-3545	TW4 Torch 4m euro adaptor;TW4枪 4m 欧式中央插头
	JDU5923	X415-3545	Tw4 Torch 4.6m euro adaptor;TW4枪 4.6m 欧式中央插头
	JDU5924	M410-3545	Tw4 Torch 3m Miller adaptor;TW4枪 3m 米勒后接口
	JDU5925	M412-3545	Tw4 Torch 4m Miller adaptor;TW4枪 4m 米勒后接口
	JDU5931	M415-3545	Tw4 Torch 4.6m Miller adaptor;TW4枪 4.6m 米勒后接口



Note: About the registered trade mark, reference number of the model of the machine and spare parts, please see inner cover (company introduction)
注:关于在注册商标、机器及配件的参考编号的注解, 请见封面内页(公司简介)

TW-500



Technical data	技术参数
Cooling 冷却方式	Gas Cooled 气冷
Duty cycle 60% 暂载率60%	400Amp CO ₂ , 350Amp MIX
Wire Size 焊丝直径	Φ 0.8-2.0mm

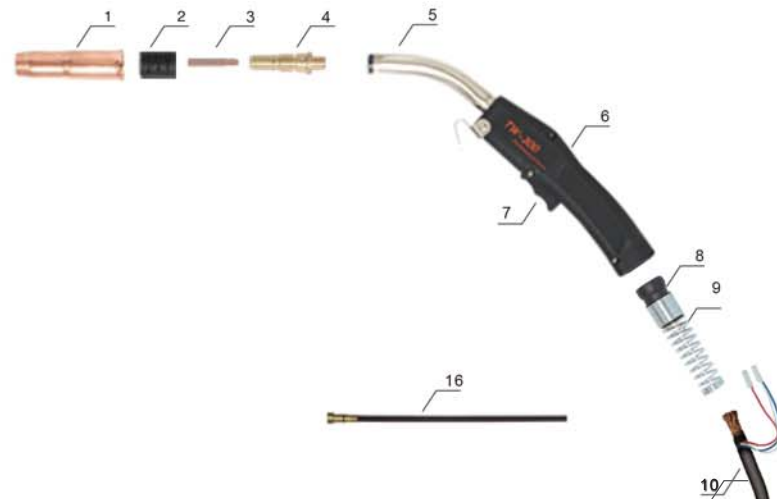

Position	Code	Ref.	Description
1	JDT0748	25CT62	Gas nozzle Φ 16; 喷嘴 Φ 16mm
2	JDT0749	35CT	Insulator; 绝缘筒
3	JDV0019-16	14-116	Contact tip 1/16"; 导电嘴 1/16"
4	JDG0087	55	Diffuser; 分流器
5	JDA0097-01	65J-60	Conductor tube 60°; 枪颈 60°
6	JDW0765	85	MIG handle with screw; MIG手柄带螺丝
7	JIR0092	94R	Trigger Kit/TW; 开关套件/TW
8	JIK0788		Joint for MIG handle; MIG手柄用球头
9	JGU0887-02		Spring for cable support/Zin/Long/TW; 电缆支撑用弹簧/镀白锌/加长/TW
10	JDO0705		Cable assembly/3M; 电缆组/3米
11	JGU0835		Spring for cable support/Blue and white zinc plating; 电缆支撑用弹簧/镀蓝白锌
12	JIK0883		Back box with closing ring; 后把套/含锁紧环
13	JGU0074	EA0018	Screw M4x6; 螺丝 M4x6
14	JAI7062		Continental adapter / Miller M10X1; 欧式转换接头/米勒 M10X1
15	JUP0003		Connetecing adaptor TW1-4; 转接头连杆/TW1-4
16	JJD0010-03		Steel liner 3.4M 0.9-1.2/TW; 钢送丝管 3.4米 0.9-1.2/TW
Complete Torch			
	JDU5511		TW5 Torch 3m; TW5枪 3m
	JDU5517		TW5 Torch 4m; TW5枪 4m
	JDU5518	515-116	TW5 Torch 4.6m; TW5枪 4.6m
	JDU5526		TW5 Torch 3m euro adaptor; TW5枪 3m 欧式中央插头
	JDU5522		TW5 Torch 4m euro adaptor; TW5枪 4m 欧式中央插头
	JDU5523		TW5 Torch 4.6m euro adaptor; TW5枪 4.6m 欧式中央插头
	JDU5524	X515-116	TW5 Torch 3m Miller adaptor; TW5枪 3m 米勒后接口
	JDU5525	M515-116	TW5 Torch 4m Miller adaptor; TW5枪 4m 米勒后接口
	JDU5531		TW5 Torch 4.6m Miller adaptor; TW5枪 4.6m 米勒后接口



Note: About the registered trade mark, reference number of the model of the machine and spare parts, please see inner cover (company introduction)
注: 关于在注册商标、机器及配件的参考编号的注解, 请见封面内页 (公司简介)

SUPER MAXI 150



Technical data	技术参数
Cooling 冷却方式	Gas Cooled 气冷
Duty cycle 60% 暂载率60%	180Amp CO ₂ , 140Amp MIX
Wire Size 焊丝直径	Φ 0.6-1.2mm

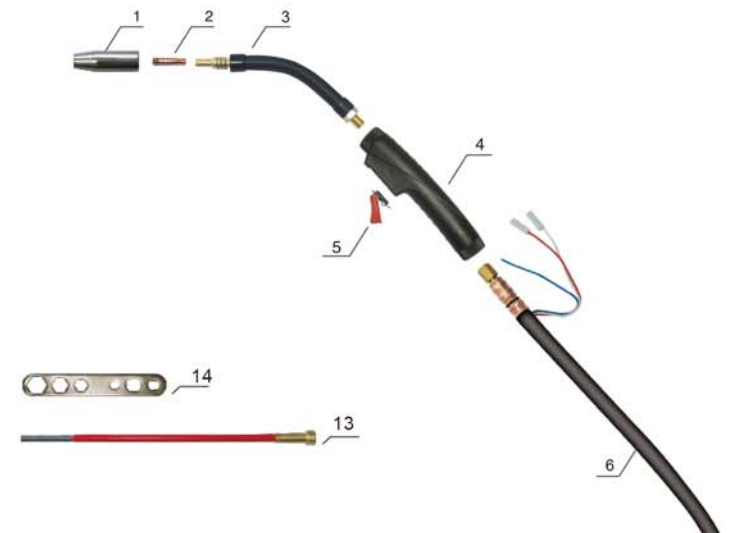

Position	Code	Ref.	Description
1	JDT0012	MC0006	Gas Nozzle Φ 14; 喷嘴 Φ 14
2	JDV0014-08	MD0008-08	Contact tip Φ 0.8; 导电嘴 Φ 0.8
3	JDA0018	MF0002	Torch head; 枪颈
4	JDW0068	MP0052	Handle; 手柄
5	JIR0081	BX0020	Trigger; 焊枪用开关
6	JDO0871	MH0310	Coaxial cable; 电缆组
7	JGU0808	EA0342	Spring cable support; 支撑弹簧
8	JIK0656	BW0195	Back box; 后把套
9	JGU0074	EA0018	Screw; 螺丝
10	JIK0074	BW0018	Adaptor nut; 焊枪锁紧螺母
11	JUC0049	AR0083	Central adaptor TW/Euro M12x1/Spring pins; 中央接头 TW/Euro M12x1/弹性针
12	JAU0083	FA0027	Liner nut M11x1; 送丝管锁紧螺母 M11x1
13	JJD0077-03		Steel liner 3.4m 0.8-1.0mm; 送丝管 3.4m 0.8-1.0mm
14	JDH6011		Spanner for MIG; MIG焊枪扳手
Complete Torch			
	JDU1626	MA6165	MIG MAX150 torch 3m Euro/TW with spring pins; 焊枪 MAX150/3m/弹性针/欧式
	JDU1622	MA6166	MIG MAX150 torch 4m Euro/TW with spring pins; 焊枪 MAX150/4m/弹性针/欧式
	JDU1623	MA6167	MIG MAX150 torch 4.6m Euro/TW with spring pins; 焊枪 MAX150/4.6m/弹性针/欧式

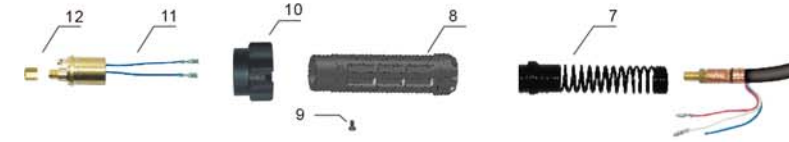

Note: About the registered trade mark, reference number of the model of the machine and spare parts, please see inner cover (company introduction)
注: 关于在注册商标、机器及配件的参考编号的注解, 请见封面内页 (公司简介)

SUPER MAXI 250



Technical data	技术参数
Cooling 冷却方式	Gas Cooled 气冷
Duty cycle 60% 暂载率60%	180Amp CO ₂ , 140Amp MIX
Wire Size 焊丝直径	Φ0.6-1.2mm

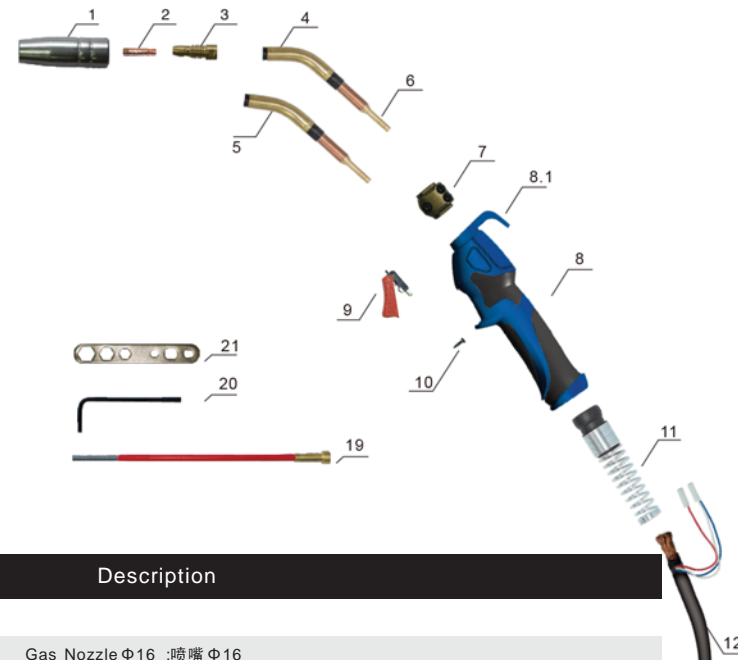

Position	Code	Ref.	Description
1	JDT0684	MC0128	Gas Nozzle Φ16 ;喷嘴 Φ16
2	JDV0019-10	MD0003-10	Contact tip Φ 1.0;导电嘴 Φ 1.0
3	JDG0017	ME0001	Gas diffuser ;分流器
4	JDA0630		Torch head 45°;枪头 45°
5	JDA0639		Torch head 60°;枪头 60°
6	JUZ0083	AU0027	Gas Hose Nipple;接头
7	JDH0031	MT0070	Adjusting Block Kit Clamp;定位块
8	JDW0866-01		Handle;手柄
8.1	JIK0683		Hanger for handle MAXI250 Φ 16;MAXI 手柄用挂钩MAXI250 Φ 16
9	JIR0081	BX0020	Trigger;焊枪用开关
10	JGU0885		Screw 3.0x10;螺丝 3.0x10
11	JIK0788	BW0319	Joint with spring;带弹簧球节
12	JDO0709	MH0243	Coaxial cable 3m;电缆组 3m
13	JGU0808-01	EA0342	Spring cable Support;支撑弹簧
14	JIK0656	BW0195	Back box;后把套
15	JGU0074	EA0018	Screw M4x6;螺丝 M4x6
16	JIK0081	BW0020	Gun plug nut;焊枪锁紧螺母
17	JUC0049	AR0083	Central adaptor TW/Euro M12x1/Spring pins;中央接头 TW/Euro M12x1/弹性针
18	JAU0083	FA0027	Liner nut M11x1;送丝管锁紧螺母 M11x1
19	JJD0078-06		Steel line 3.0m 0.8-0.9mm;送丝管 3.0m 0.8-0.9mm
20	JDH6018		Spanner for Pan torch: 日式枪用六角扳手
21	JDH6011		Spanner for MIG;MIG 焊枪扳手
Complete Torch			
	JDU1726-36	MA6265	MIG MAXI 250 torch 3m with spring pins;焊枪 MAXI 250/3m/弹性针
	JDU1722-36	MA6266	MIG MAXI 250 torch 4m with spring pins;焊枪 MAXI 250/4m/弹性针
	JDU1723-36	MA6267	MIG MAXI 250 torch 5m with spring pins;焊枪 MAXI 250/5m/弹性针

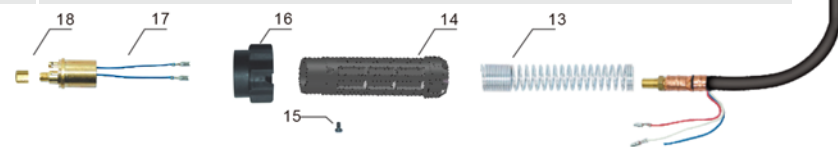

Note: About the registered trade mark, reference number of the model of the machine and spare parts, please see inner cover (company introduction)
注:关于在注册商标、机器及配件的参考编号的注解, 请见封面内页(公司简介)

SUPER MAXI 350



Technical data	技术参数
Cooling 冷却方式	Gas Cooled 气冷
Duty cycle 60% 暂载率60%	400Amp CO ₂ , 300Amp MIX
Wire Size 焊丝直径	Φ0.8-1.6mm

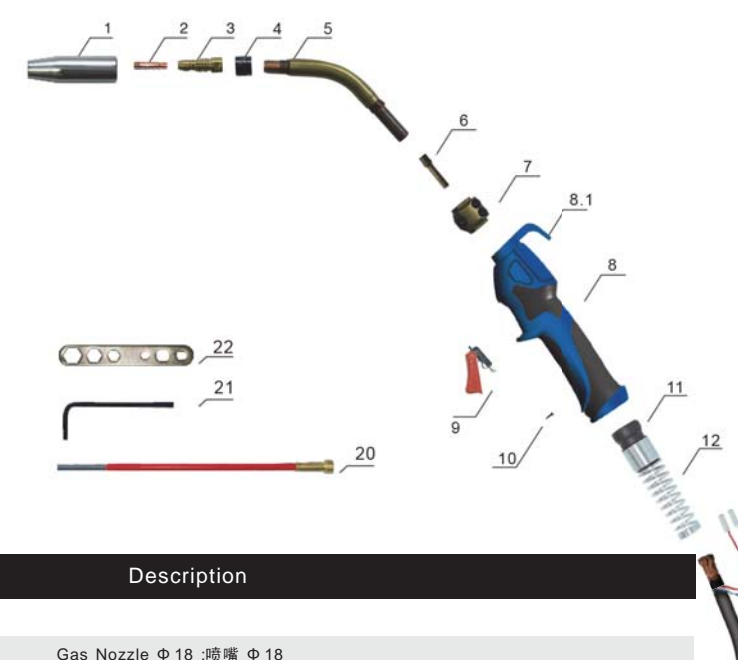

Position	Code	Ref.	Description
1	JDT0078	MC0012	Gas Nozzle Φ 18 ;喷嘴 Φ 18
2	JDV0010-12	MD0004-12	Contact tip Φ 1.2;导电嘴 Φ 1.2
3	JDG0019	ME0003	Gas diffuser;分流器
4	JDL0648	MQ0182	Insulator for Torch head;绝缘环
5	JDA0703	MF0247	Torch head ;枪头
6	JUZ0695	AU0028	Back fitting coaxial cable ;电缆接头
7	JDH0038	MT0072	Adjusting Block Kit Clamp;定位块
8	JDW0866-01		Handle;手柄
8.1	JIK0681		Hanger for handle Φ 18;MAXI 手柄用挂钩 Φ 18
9	JIR0081	BX0020	Trigger;焊枪用开关
10	JGU0885		Screw 3.0x10;螺丝 3.0x10
11	JIK0788	BW0222	Joint for MIG handle;MIG手柄用球头
12	JGU0887-01		Spring for cable support/Blue and white zinc plating;电缆支撑用弹簧/镀蓝白锌
13	JDO0702	MH0246	Coaxial cable 3m;电缆组 3m
14	JGU0835		Spring for cable support/Blue and white zinc plating;电缆支撑用弹簧/镀蓝白锌
15	JIK0883		Back box with closing ring;后把套/含锁紧环
16	JGU0074	EA0018	Screw M4x6;螺丝 M4x6
17	JIK0081		Adaptor nut;焊枪锁紧螺母
18	JUC0049	AR0083	Central adaptor TW/Euro M12x1/Spring pins;中央接头 TW/Euro M12x1/弹性针
19	JAU0083	FA0027	Liner nut M11x1;送丝管锁紧螺母 M11x1
20	JJD0079-06		Steel liner 3.4m 1.2-1.6mm;送丝管 3.4m 1.2-1.6mm
21	JDH6018		Spanner for pan torch: 日式枪用六角扳手
22	JDH6011		Spanner for MIG;MIG 焊枪扳手
Complete Torch			
	JDU1826-36	MA6365	MIG MAXI 350 torch 3m with spring pins;焊枪 MAXI 350/3m/弹性针
	JDU1822-36	MA6366	MIG MAXI 350 torch 4m with spring pins;焊枪 MAXI 350/4m/弹性针
	JDU1823-36	MA3667	MIG MAXI 350 torch 5m with spring pins;焊枪 MAXI 350/5m/弹性针



Note: About the registered trade mark, reference number of the model of the machine and spare parts, please see inner cover (company introduction)
注:关于在注册商标、机器及配件的参考编号的注解, 请见封面内页(公司简介)

SUPER MAXI 450



Technical data	技术参数
Cooling 冷却方式	Gas Cooled 气冷
Duty cycle 60% 暂载率60%	500Amp CO ₂ , 400Amp MIX
Wire Size 焊丝直径	Φ0.8-2.0mm

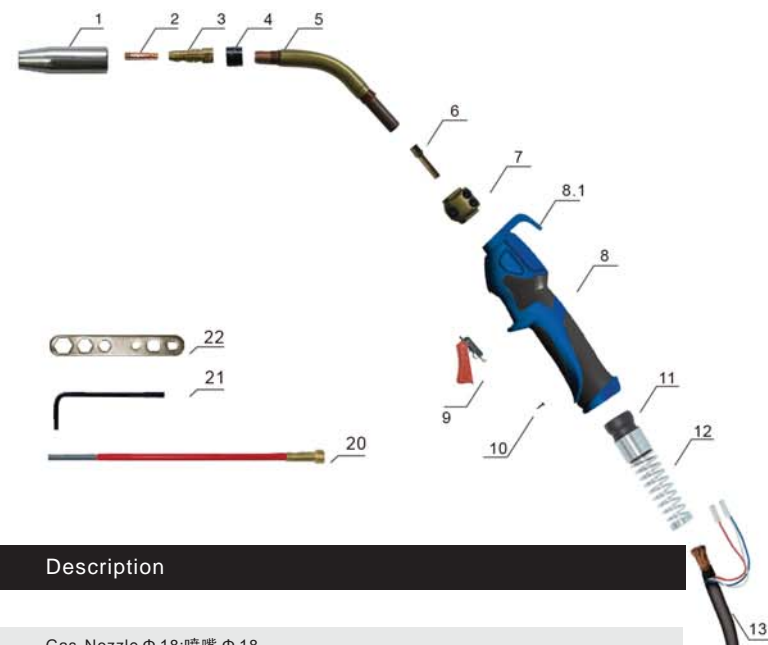

Position	Code	Ref.	Description
1	JDT0078	MC0012	Gas Nozzle Φ 18;喷嘴 Φ 18
2	JDV0016-12	MD0005-12	Contact tip Φ 1.2/M8;导电嘴 Φ 1.2/M8
3	JDG0012	ME0006	Gas diffuser ;分流器
4	JDL0648	MF0182	Insulator for Torch head;绝缘环
5	JDA0042	MF0086	Torch head ;枪颈
6	JUZ0695	AU0028	Back fitting coaxial cable of MAXI;MAXI 枪电缆接头
7	JDH0038	MT0072	Adjusting Block Kit Clamp;定位块
8	JDW0866-01		Handle;手柄
8.1	JIK0684		Hanger for handle Φ 20;MAXI 手柄用挂钩Φ 20
9	JIR0081	BX0020	Trigger;焊枪用开关
10	JGU0885		Screw 3.0x10;螺丝 3.0x10
11	JIK0788	BW0222	Joint for MIG handle;MIG手柄用球头
12	JGU0887-01		Spring for cable support/Blue and white zinc plating;电缆支撑用弹簧/镀蓝白锌
13	JDO0705	Mh0249	Coaxial cable 3m;电缆组 3m
14	JGU0835		Spring for cable support/Blue and white zinc plating;电缆支撑用弹簧/镀蓝白锌
15	JIK0883		Back box with closing ring;后把套/含锁紧环
16	JGU0074	EA0018	Screw M4x6;螺丝 M4x6
17	JIK0081		Adaptor nut;焊枪锁紧螺母
18	JUC0049	AR0083	Central adaptor TW/Euro M12x1/Spring pins;中央接头 TW/Euro M12x1/弹性针
19	JAU0083	FA0027	Liner nut M11x1;送丝管锁紧螺母 M11x1
20	JJD0079-06		Steel liner 3.4m 1.2-1.6mm;送丝管 3.4m 1.2-1.6mm
21	JDH6018		Spanner for pan torch;日式枪用六角扳手
22	JDH6011		Spanner for MIG;MIG 焊枪扳手
Complete Torch			
	JDU1926-36	MA6465	MIG MAXI 450 torch 3m with spring pins;焊枪 MAXI 450/3m/弹性针
	JDU1922-36	MA6466	MIG MAXI 450 torch 4m with spring pins;焊枪 MAXI 450/4m/弹性针
	JDU1923-36	MA6467	MIG MAXI 450 torch 5m with spring pins;焊枪 MAXI 450/5m/弹性针



Note: About the registered trade mark, reference number of the model of the machine and spare parts, please see inner cover (company introduction)
注:关于在注册商标、机器及配件的参考编号的注解,请见封面内页(公司简介)

SUPER MAXI 4000



Technical data	技术参数
Cooling 冷却方式	Water Cooled 水冷
Duty cycle 100% 暂载率100%	400Amp CO ₂ , 350Amp MIX
Wire Size 焊丝直径	Φ1.0-2.4mm

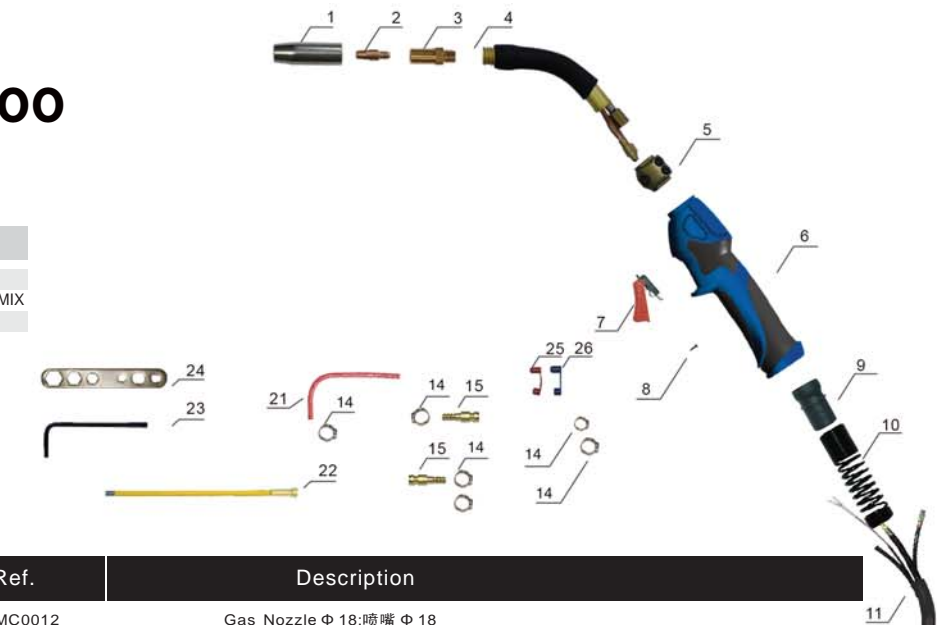

Position	Code	Ref.	Description
1	JDT0078	MC0012	Gas Nozzle Φ 18;喷嘴 Φ 18
2	JDV0016-12	MD0005-12	Contact tip Φ 1.2/M8;导电嘴 Φ 1.2/M8
3	JDG0015	ME0009	Gas diffuser;分流器
4	JDJ0072	MG0016	Torch head;枪颈
5	JDH0038	MT0072	Adjusting Block Kit Clamp;定位块
6	JDW0866-01		Handle;手柄
7	JIR0081	BX0020	Trigger;焊枪用开关
8	JGU0885		Screw 3.0x16;螺丝 3.0x16
9	JIK0788	BX0222	Joint for MIG handle;手柄用球头
10	JGU0881	EA0320	Spring cable support;电缆支撑用弹簧
11	JDE0088	MN0022	Cable assenbly;水电缆组
12	JIK0726	BW0265	Handle closing ring;手柄锁紧环
13	JIK0774		Back box for water cooled torches;水冷枪后把套
14	JGU0733		Clamp Φ 9.0mm;卡箍 Φ 9.0mm
15	JAU8081		Quick connector water Φ 6mm;水冷快速插头 Φ 6mm
16	JGU0074		Screw M4x6;螺丝 M4x6
17	JGU0775		Hose support for water cooled rear box;水管支柱
18	JIK0083		Adaptor nut /Blue;锁紧螺母/蓝色
19	JUC0618	AR0102	Euro centre adaptor/water/maxi/spring pin;欧式中央插头/水冷/MAXI/弹性针
20	JAU0082	IFA0026	Liner nut;送丝管锁紧螺母
21	JLI0616	QB0105	EPDM output water tube Φ 5x8mm 0.8m red;EPDM 出水管 Φ 5x8mm 0.8m Red
22	JJD0501	GM0540	Insulated Steel Liner 1.2-1.6/3m/Yellow;带绝缘层送丝管 1.2-1.6/3m/黄色
23	JDH6018	EA0297	Spanner for pan torch;日式枪用六角扳手
24	JDH6011		Spanner for MIG;MIG 焊枪扳手
25	JIK0317		Plastic support for water cooling connector red水堵/红色
26	JIK0319		Plastic support for water cooling connector blue水堵/蓝色
Complete Torch			
	JDI7809-36	MB2343	MIG MAXI 4000 torch 3m with spring pins;焊枪 MAXI 4000/3m/弹性针
	JDI7800-36	MB2344	MIG MAXI 4000 torch 4m with spring pins;焊枪 MAXI 4000/4m/弹性针
	JDI7806-36	MB2345	MIG MAXI 4000 torch 5m with spring pins;焊枪 MAXI 4000/5m/弹性针



Note: About the registered trade mark, reference number of the model of the machine and spare parts, please see inner cover (company introduction)
注:关于在注册商标、机器及配件的参考编号的注解,请见封面内页(公司简介)

SPARE PARTS 配件

SUITABLE FOR FORNIUS 弗尼斯式
AL 4000/AW 5000

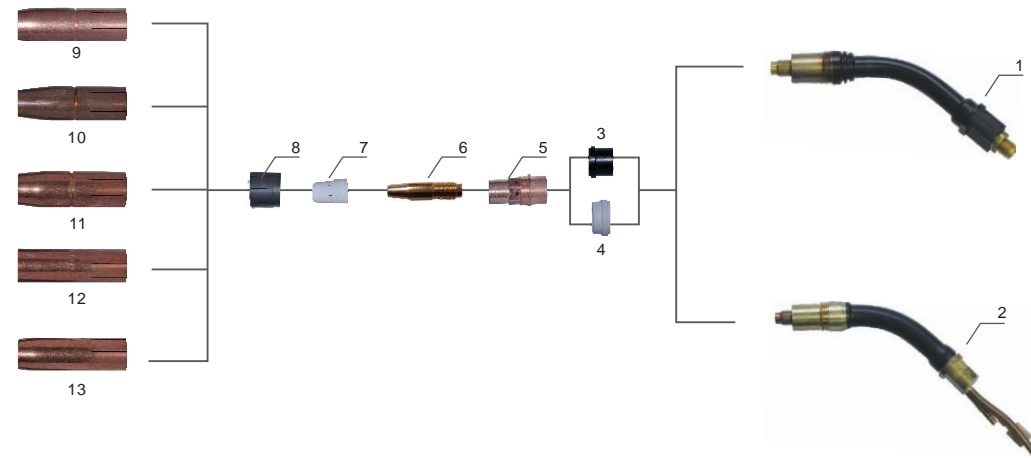

Position	Code	Ref.	Description
1	JDA0970	34.0350.1822	Torch head AL4000 45°;AL4000 枪头 45°
2	JDJ0770	34.0350.1820	Torch head AW5000 45°;AW5000 枪头 45°
3	JAI1242	42.0100.1018	Insulator Φ 14.1/ Φ 21x16(AL4000);绝缘环 Φ 14.1/ Φ 21x16(AL4000)
4	JAI1246	42.0100.1016	Insulator Φ 15/ Φ 21x10(AW5000);绝缘环 Φ 15/ Φ 21x10(AW5000)
5	JDG0014	42.0001.5122	Contact tip holder M10x1.25/SW13x32;导电嘴座 M10x1.25/SW13x32
6	JDV0818-16		Contact tip;导电嘴
7	JDG0543	42.0001.1007	White ceramic gas diffuser;白色陶瓷分流器
8	JAG0056	42.0001.2970	Retaining sleeve (AL4000/AW5000);喷嘴护套 (AL4000/AW5000)
9	JDT0807	42.0001.5128	Gas Nozzle Φ 17/ Φ 25x79.3;外喷嘴 Φ 17/ Φ 25x79.3
10	JDT0801	42.0001.5129	Gas Nozzle Φ 15/ Φ 25x79.3;外喷嘴 Φ 15/ Φ 25x79.3;
11	JDT0803	42.0001.5607	Gas Nozzle Φ 17/ Φ 25x74.5;外喷嘴 Φ 17/ Φ 25x74.5/短款
12	JDT0804	42.0001.5127	Gas Nozzle Φ 20/ Φ 25x79.3;外喷嘴 Φ 20/ Φ 25x79.3
13	JDT0805	42.0001.5130	Gas Nozzle Φ 17/ Φ 25x79.3;外喷嘴 Φ 17/ Φ 25x79.3/短款



Note: About the registered trade mark, reference number of the model of the machine and spare parts, please see inner cover (company introduction)
注:关于在注册商标、机器及配件的参考编号的注解, 请见封面内页 (公司简介)

CONTACT TIPS 导电嘴

SUITABLE FOR BINZEL PANASONIC

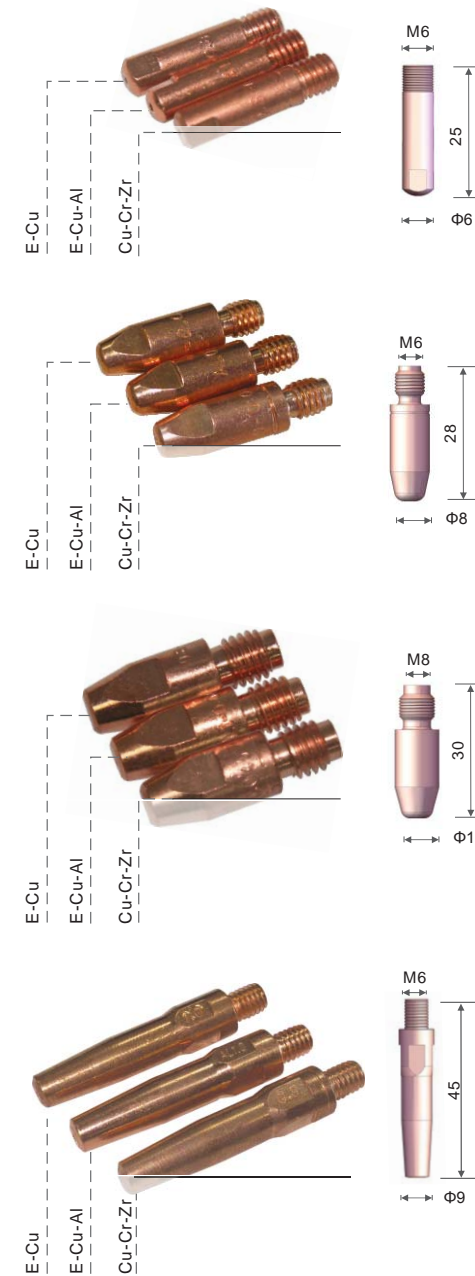

E-Cu			E-Cu-Al			Cu-Cr-Zr		
Code	Ref.	Wire	Code	Ref.	Wire	Code	Ref.	Wire
JDV0014-06	140.0008	Φ 0.6	JDV0014-58	141.0002	Φ 0.8	JDV0014-76	140.0855	Φ 0.6
JDV0014-08	140.0059	Φ 0.8	JDV0014-59		Φ 0.9	JDV0014-78	140.0662	Φ 0.8
JDV0014-09	140.0177	Φ 0.9	JDV0014-60	141.0007	Φ 1.0	JDV0014-80	140.0256	Φ 1.0
JDV0014-10	140.0253	Φ 1.0	JDV0014-62		Φ 1.2	JDV0014-82		Φ 1.2

E-Cu			E-Cu-Al			Cu-Cr-Zr		
Code	Ref.	Wire	Code	Ref.	Wire	Code	Ref.	Wire
JDV0015-06	140.0005	Φ 0.6	JDV0015-58	141.0001	Φ 0.8	JDV0015-78	140.0054	Φ 0.8
JDV0015-08	140.0051	Φ 0.8	JDV0015-59		Φ 0.9	JDV0015-80	140.0245	Φ 1.0
JDV0015-10	140.0242	Φ 1.0	JDV0015-60	141.0006	Φ 1.0	JDV0015-82	140.0382	Φ 1.2
JDV0015-12	140.0379	Φ 1.2	JDV0015-62	141.0010	Φ 1.2			
JDV0015-16	140.0555	Φ 1.6	JDV0015-66	141.0020	Φ 1.6			

E-Cu			E-Cu-Al			Cu-Cr-Zr		
Code	Ref.	Wire	Code	Ref.	Wire	Code	Ref.	Wire
JDV0016-08	140.0114	Φ 0.8	JDV0016-58	141.0003	Φ 0.8	JDV0016-78	140.0117	Φ 0.8
JDV0016-10	140.0313	Φ 1.0	JDV0016-59		Φ 0.9	JDV0016-80	140.0316	Φ 1.0
JDV0016-12	140.0442	Φ 1.2	JDV0016-60	141.0008	Φ 1.0	JDV0016-82	140.0445	Φ 1.2
JDV0016-16	140.0587	Φ 1.6	JDV0016-62	141.0015	Φ 1.2	JDV0016-84		Φ 1.4
JDV0016-20	140.0653	Φ 2.0	JDV0016-66	141.0022	Φ 1.6	JDV0016-86	140.0590	Φ 1.6
JDV0016-24	140.0677	Φ 2.4	JDV0016-70		Φ 2.0			
			JDV0016-74		Φ 2.4			

E-Cu			E-Cu-Al			Cu-Cr-Zr		
Code	Ref.	Wire	Code	Ref.	Wire	Code	Ref.	Wire
JDV0757-08		Φ 0.8	JDV0757-60		Φ 1.0	JDV0757-78		Φ 0.8
JDV0757-10		Φ 1.0	JDV0757-62		Φ 1.2	JDV0757-79		Φ 0.9
JDV0757-12		Φ 1.2	JDV0757-64		Φ 1.4	JDV0757-80		Φ 1.0
JDV0757-14		Φ 1.4				JDV0757-82		Φ 1.2
JDV0757-16		Φ 1.6				JDV0757-84		Φ 1.4
						JDV0757-86		Φ 1.6
						JDV0757-100		Φ 1.0AL
						JDV0757-102		Φ 1.2AL



Note: About the registered trade mark, reference number of the model of the machine and spare parts, please see inner cover (company introduction)
注:关于在注册商标、机器及配件的参考编号的注解, 请见封面内页 (公司简介)

CONTACT TIPS 美式导电嘴



SUITABLE FOR TWECO
BERNARD
ESAB
LINCOLN
MILLER
SAF
TREGASKISS
INTERCHANGEABLE AT REQUEST



E-Cu		
Code	Ref.	Wire
JDV0773-06	11-23	Φ0.6
JDV0773-08	11-30	Φ0.8
JDV0773-09	11-35	Φ0.9
JDV0773-10	11-40	Φ1.0
JDV0773-12	11-45	Φ1.2



E-Cu		
Code	Ref.	Wire
JDV0774-08	11H-30	Φ0.8
JDV0774-09	11H-35	Φ0.9
JDV0774-10	11H-40	Φ1.0
JDV0774-12	11H-45	Φ1.2



E-Cu		
Code	Ref.	Wire
JDV0775-06	11T-23	Φ0.6
JDV0775-08	11T-30	Φ0.8
JDV0775-09	11T-35	Φ0.9
JDV0775-10	11T-40	Φ1.0
JDV0775-12	11T-45	Φ1.2

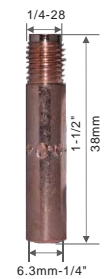

E-Cu		
Code	Ref.	Wire
JDV0019-06	14-23	Φ0.6
JDV0019-08	14-30	Φ0.8
JDV0019-09	14-35	Φ0.9
JDV0019-10	14-40	Φ1.0
JDV0019-12	14-45	Φ1.2
JDV0019-13	14-52	Φ1.3
JDV0019-16	14-116	Φ1.6
JDV0019-20	14-564	Φ2.0
JDV0019-62	14A-364	Φ1.2
JDV0019-66	14A-116	Φ1.6



E-Cu		
Code	Ref.	Wire
JDV0779-06	14T-23	Φ0.6
JDV0779-08	14T-30	Φ0.8
JDV0779-09	14T-35	Φ0.9
JDV0779-10	14T-40	Φ1.0
JDV0779-12	14T-45	Φ1.2
JDV0779-13	14T-52	Φ1.3
JDV0779-16	14T-116	Φ1.6



E-Cu		
Code	Ref.	Wire
JDV0010-09	14H-35	Φ0.9
JDV0010-10	14H-40	Φ1.0
JDV0010-12	14H-45	Φ1.2
JDV0010-13	14H-52	Φ1.3
JDV0010-16	14H-116	Φ1.6
JDV0010-20	14H-564	Φ2.0
JDV0010-62	14AH-364	Φ1.2
JDV0010-66	14AH-116	Φ1.6



E-Cu		
Code	Ref.	Wire
JDV0772-09	14HT-35	Φ0.9
JDV0772-10	14HT-40	Φ1.0
JDV0772-12	14HT-45	Φ1.2
JDV0772-13	14HT-52	Φ1.3
JDV0772-16	14HT-116	Φ1.6
JDV0772-20	14HT-564	Φ2.0



E-Cu		
Code	Ref.	Wire
JDV0071-09	15H35	Φ0.9
JDV0071-12	15H45	Φ1.2
JDV0071-14	15H52	Φ1.4
JDV0071-16	15H116	Φ1.6
JDV0071-20	15H564	Φ2.0
JDV0071-24	15H332	Φ2.4
JDV0071-28	15H764	Φ2.8



E-Cu		
Code	Ref.	Wire
JDV0072-09	15HFC35	Φ0.9
JDV0072-12	15HFC45	Φ1.2
JDV0072-13	15HFC52	Φ1.3
JDV0072-16	15HFC116	Φ1.6
JDV0072-20	15HFC564	Φ2.0
JDV0072-24	15HFC332	Φ2.4
JDV0072-28	15HFC764	Φ2.8
JDV0072-32	15HFC18	Φ3.2
JDV0072-62	15AHFC364	Φ1.2 AL
JDV0072-66	15AHFC116	Φ1.6 AL

NOZZLES 喷嘴



SUITABLE FOR BINZEL

MIG 15

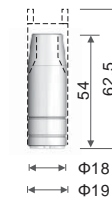

MIG 24/240

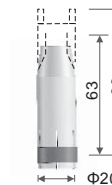

MIG 25



MIG 26/400/500

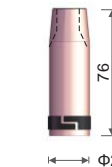

MIG 36



Code	Ref.	Description	Pack
JDT0073	145.0123	Gas nozzle Φ 9.5mm;喷嘴 Φ 9.5mm/15AK	10
JDT0074	145.0075	Gas nozzle Φ 12mm;喷嘴 Φ 12mm/15AK	10
JDT0075	145.0041	Gas nozzle Φ 16mm;喷嘴 Φ 16mm/15AK	10
JDT0081	145.0183	Spot welding gas nozzle Φ 16mm;点焊喷嘴 Φ 16mm/15AK	10
JDT0722	145.0143	Tapered gas nozzle Φ 13mm;锥型喷嘴 Φ 13mm/15AK	10

Code	Ref.	Description	Pack
JDT0811	145.0047	Gas nozzle Φ 17mm;喷嘴 Φ 17mm/24KD	10
JDT0817	145.0080	Gas nozzle Φ 12.5mm;喷嘴 Φ 12.5mm/24KD	10
JDT0818	145.0128	Gas nozzle Φ 10mm;喷嘴 Φ 10mm/24KD	10
JDT0819	145.0174	Spot welding gas nozzle;点焊喷嘴/24AK	10

Code	Ref.	Description	Pack
JDT0088	145.0124	Gas nozzle Φ 11mm;喷嘴 Φ 11mm/25AK	10
JDT0089	145.0100	Gas nozzle Φ 15mm;喷嘴 Φ 15mm/25AK	10
JDT0080	145.0042	Gas nozzle Φ 18mm;喷嘴 Φ 18mm/25AK	10
JDT0726	145.0153	Tapered gas nozzle Φ 11mm;锥型喷嘴 Φ 11mm/25AK	10
JDT0723	145.0214	Tapered gas nozzle Φ 14mm;锥型喷嘴 Φ 14mm/25AK	10
JDT0086	145.0169	Spot welding gas nozzle Φ 18mm;点焊喷嘴 Φ 18mm/25AK	10

Code	Ref.	Description	Pack
JDT0724	145.0085	Gas nozzle Φ 16mm;喷嘴 Φ 16mm/401D-501D	10
JDT0751	145.0132	Gas nozzle Φ 14mm;喷嘴 Φ 14mm/401D-501D	10
JDT0757	145.0051	Gas nozzle Φ 19mm;喷嘴 Φ 19mm/401D-501D	10
JDT0758	145.0148	Adjusted tapered nozzle Φ 15mm;喷嘴 Φ 15mm/401D-501D	10
JDT0759	145.0179	Spot welding gas nozzle Φ 20mm;点焊喷嘴 Φ 20mm/401D-501D	10

Code	Ref.	Description	Pack
JDT0082	145.0126	Gas nozzle Φ 12mm;喷嘴 Φ 12mm/36KD	10
JDT0083	145.0078	Gas nozzle Φ 16mm;喷嘴 Φ 16mm/36KD	10
JDT0084	145.0045	Gas nozzle Φ 19mm;喷嘴 Φ 19mm/36KD	10
JDT0671	145.0172	Spot welding gas nozzle Φ 20mm;点焊喷嘴 Φ 20mm/36KD	10



Note: About the registered trade mark, reference number of the model of the machine and spare parts, please see inner cover (company introduction)
注:关于在注册商标、机器及配件的参考编号的注解,请见封面内页(公司简介)



Note: About the registered trade mark, reference number of the model of the machine and spare parts, please see inner cover (company introduction)
注:关于在注册商标、机器及配件的参考编号的注解,请见封面内页(公司简介)

NOZZLES 喷嘴

SUITABLE FOR BINZEL



MIG 40KD

Code	Ref.	Description	Pack
JDT0711	145.0079	Gas nozzle Φ 18mm 40KD; 喷嘴 Φ 18mm 40KD	10
JDT0712	145.0046	Gas nozzle Φ 21mm 40KD; 喷嘴 Φ 21mm 40KD	10
JDT0713	145.0127	Gas nozzle Φ 14mm 40KD; 喷嘴 Φ 14mm 40KD	10

SUITABLE FOR MIG MAXI

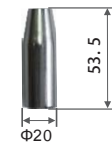

Code	Ref.	Description	Pack
JDT0012	MC 0006	Gas nozzle Φ 14mm MAXI150; 喷嘴 Φ 14mm MAXI150	10
JDT0013	MC 0007	Spot Welding Gas Nozzle; 点焊喷嘴	10
JDT0016	MC 0005	Gas nozzle Φ 11mm MAXI150; 喷嘴 Φ 11mm MAXI150	10

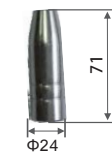

Code	Ref.	Description	Pack
JDT0014	MC 0008	Gas nozzle Φ 11mm MAXI250; 喷嘴 Φ 11mm MAXI250	10
JDT0015	MC 0009	Gas nozzle Φ 14mm MAXI250; 喷嘴 Φ 14mm MAXI250	10
JDT0071	MC 0010	Gas Nozzle Φ 18mm; 喷嘴 Φ 18mm	10
JDT0684	MC 0128	Gas nozzle Φ 16mm MAXI250; 喷嘴 Φ 16mm MAXI250	10
JDT0685	MC 0129	Tapered Gas Nozzle Φ 14mm; 圆锥喷嘴 Φ 14mm	10

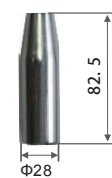

Code	Ref.	Description	Pack
JDT0077	MC 0011	Gas nozzle Φ 16mm MAXI350; 喷嘴 Φ 16mm MAXI350	10
JDT0078	MC 0012	Gas nozzle Φ 18mm MAXI350; 喷嘴 Φ 18mm MAXI350	10
JDT0079	MC 0013	Gas nozzle Φ 20mm MAXI350; 喷嘴 Φ 20mm MAXI350	10
JDT0754	MC 0298	Nozzle Φ 14mm; 喷嘴 Φ 14mm	10

TW TYPE NOZZLES 美式喷嘴

SUITABLE FOR TWECO



Type	Image	Code	Ref.	Description
TW2-TW4		JDT0588	24AT-37SS	Gas nozzle 3/8" (Φ9.5mm); 喷嘴 Φ9.5mm
		JDT0095	24CT-50S	Gas nozzle 1/2" (Φ12.7mm); 喷嘴 Φ12.7mm
		JDT0001	24CT-62S	Gas nozzle 5/8" (Φ16mm); 喷嘴 Φ16mm
		JDT0007	24CT-75S	Gas nozzle 3/4" (Φ19mm); 喷嘴 Φ19mm
		JDT0703	24CT-37S	Gas nozzle 3/8" (Φ9.5mm); 喷嘴 Φ9.5mm
		JDT0784	24CT-50F	Gas nozzle 1/2" (Φ12.7mm); 喷嘴 Φ12.7mm
		JDT0785	24CT-62F	Gas nozzle 5/8" (Φ16mm); 喷嘴 Φ16mm
		JDT0791	24CT-75F	Gas nozzle 3/4" (Φ19mm); 喷嘴 Φ19mm
		JDT0797	24CT-62R	Gas nozzle 5/8" (Φ16mm); 喷嘴 Φ16mm
		JDT0798	24CT-72R	Gas nozzle 3/4" (Φ19mm); 喷嘴 Φ19mm
	JDT0586	24FN-75S	Gas nozzle 3/4" (Φ19mm); 喷嘴 Φ19mm	
	JDT0589	24FN-50S	Gas nozzle 1/2" (Φ12.7mm); 喷嘴 Φ12.7mm	
	JDT0580	24FN-62S	Gas nozzle 5/8" (Φ16mm); 喷嘴 Φ16mm	
	JDT0582	24FN-62R	Gas nozzle 5/8" (Φ16mm) L=52.3mm; 喷嘴 Φ16mm	
	JDT0583	24FN-62F	Gas nozzle 5/8" (Φ16mm) L=39mm; 喷嘴 Φ16mm	

Type	Image	Code	Ref.	Description
TW5		JDT0741	25CT-50	Gas nozzle 1/2" (Φ12.7mm); 喷嘴
		JDT0747	25CT-75	Gas nozzle 3/4" (Φ19mm); 喷嘴
		JDT0748	25CT-62	Gas nozzle 5/8" (Φ16mm); 喷嘴

Type	Image	Code	Ref.	Description
TW2		JDL0691	32	Insulator 32; 绝缘筒 32
TW3-TW4		JDL0697	34A	Insulator 34A; 绝缘筒 34A
TW2-TW4		JDT0096	34CT	Insulator 34CT; 绝缘筒 34CT
		JDT0740	34FN	Insulator 34FN; 绝缘筒 34FN
TW5		JDT0749	35CT	Insulator 35CT; 绝缘筒 35CT



TW TYPE NOZZLES 美式喷嘴

SUITABLE FOR TWECO



Type	Image	Code	Ref.	Description
TW1		JDT0091	21-37	Gas Nozzle 3/8" Φ 9.5mm ;喷嘴Φ 9.5mm
		JDT0097	21-50	Gas Nozzle 1/2" Φ 12.5mm ;喷嘴Φ 12.5mm
		JDT0098	21-62	Gas Nozzle 5/8" Φ 16mm ;喷嘴Φ 16mm
		JDT0511	21T-37	Gas nozzle 3/8" Φ 9.5mm ;喷嘴Φ 9.5mm
		JDT0517	21T-37F	Gas nozzle 3/8" Φ 9.5mm ;喷嘴Φ 9.5mm
		JDT0518	21-37F	Gas nozzle 3/8" Φ 9.5mm ;喷嘴Φ 9.5mm
	JDT0982	21-50F	Gas nozzle 1/2" Φ 12.5mm ;喷嘴Φ 12.5mm	
	JDT0983	21-62F	Gas nozzle 5/8" Φ 16 ;喷嘴Φ 16	

Type	Image	Code	Ref.	Description
TW2		JDT0796	22-62	Gas nozzle 5/8" Φ 16mm;喷嘴Φ 16mm
		JDT0799	22-37	Gas nozzle 3/8" (Φ 9.5mm); ;喷嘴Φ 9.5mm
		JDT0790	22-50	Gas nozzle 1/2" Φ 12.5mm; ;喷嘴Φ 12.5mm
		JDT0510	22T-37SS	Gas nozzle 3/8" (Φ 9.5mm) ;喷嘴Φ 9.5mm
		JDT0512	22-50SS	Gas nozzle 1/2" (Φ 12.5mm) ;喷嘴Φ 12.5mm
		JDT0513	22-62SS	Gas nozzle 5/8" (Φ 16mm) ;喷嘴Φ 16mm
	JDT0516	22-37SS	Gas nozzle 3/8" (Φ 9.5mm) ;喷嘴Φ 9.5mm	

Type	Image	Code	Ref.	Description
TW2-TW4		JDT0008	23-37	Gas nozzle 3/8" Φ 9.5mm;喷嘴Φ 9.5mm
		JDT0009	23-50	Gas nozzle 1/2" Φ 12.5mm;喷嘴Φ 12.5mm
		JDT0000	23-62	Gas nozzle 5/8" Φ 16mm;喷嘴Φ 16mm;
		JDT0609	23-75	Gas nozzle 3/4" Φ 19mm;喷嘴 3/4"Φ19mm
		JDT0708	23-37F	Gas nozzle ;喷嘴
		JDT0709	23-50F	Gas nozzle ;喷嘴
		JDT0700	23-62F	Gas nozzle ;喷嘴
		JDT0706	23-75F	Gas nozzle 3/4" (Φ 19mm) ;喷嘴Φ 19mm
		JDT0514	23H-50	Gas nozzle 1/2" (Φ 12.5mm) ;喷嘴Φ 12.5mm
		JDT0515	23H-62	Gas nozzle 5/8" (Φ 16mm) ;喷嘴Φ 16mm
		JDT0511	23H-75	Gas nozzle 3/8" (Φ 9.5mm) ;喷嘴Φ 9.5mm
		JDT0577	23T-37	Gas nozzle 3/8" (Φ 9.5mm);喷嘴Φ 9.5mm
		JDT0578	23T-37F	Gas nozzle 3/8" (Φ 9.5mm) ;喷嘴Φ 9.5mm
		JDT0606	24A-50	Gas nozzle 1/2" Φ 12.5mm;喷嘴Φ 12.5mm
		JDT0602	24A-62	Gas nozzle 5/8" Φ 16mm;喷嘴Φ 16mm
		JDT0603	24A-75	Gas nozzle 3/4" Φ 19mm;喷嘴Φ 19mm
		JDT0579	24A-37SS	Gas nozzle 3/8" (Φ 9.5mm) ;喷嘴Φ 9.5mm
		JDT0570	24A-50SS	Gas nozzle 1/2" (Φ 12.5mm) ;喷嘴Φ 12.5mm
		JDT0576	24A-62SS	Gas nozzle 5/8" (Φ 16mm) ;喷嘴Φ 16mm
		JDT0572	24A-75SS	Gas nozzle 3/4" (Φ 19mm) ;喷嘴Φ 19mm
		JDT0573	24AH-50	Gas nozzle 1/2" (Φ 12.5mm) ;喷嘴Φ 12.5mm
		JDT0574	24AH-62	Gas nozzle 5/8" (Φ 16mm) ;喷嘴Φ 16mm
		JDT0575	24AH-75	Gas nozzle 3/4" (Φ 19mm) ;喷嘴Φ 19mm
		JDT0581	24AH-62SS	Gas nozzle 5/8" (Φ 16mm) ;喷嘴Φ 16mm
JDT0587		24AH-72SS	Gas nozzle 3/4" (Φ 19mm) ;喷嘴Φ 19mm	



Note: About the registered trade mark, reference number of the model of the machine and spare parts, please see inner cover (company introduction)
注:关于在注册商标、机器及配件的参考编号的注解, 请见封面内页 (公司简介)

DIFFUSERS AND TIP HOLDERS 分流器及导电嘴座

SUITABLE FOR BINZEL



MIG 24/240

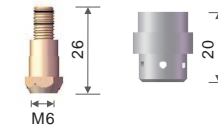

Code	Ref.	Description
○ JDG0040	012.0183	White plastic gas diffuser;白色塑料分流器/24KD
○ JDG0540		White ceramic gas diffuser;白色陶瓷分流器/24KD
● JDV0694	142.0003	Contact tip holder ;导电嘴座/M6x26mm/24KD
○ JDV0695		Contact tip holder ;导电嘴座/M6x28mm/24KD
● JDG0840		Red silicon gas diffuser;红色硅胶分流器/24KD

MIG 25

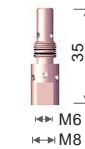

Code	Ref.	Description
● JDG0072	142.0001	Gas diffuser M6x35mm;分流器 M6x35mm/25AK
● JDG0001		Gas diffuser M8x35mm;分流器 M8x35mm/25AK

MIG 26

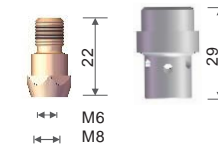

Code	Ref.	Description
● JDV0027	142.0007	Contact tip holder M6x22mm;导电嘴座M6x22mm/26KD
● JDV0028	142.0082	Contact tip holder M8x22mm;导电嘴座M8x22mm/26KD
○ JDG0046	018.0116	White plastic gas diffuser;白色塑料分流器/26KD
○ JDG0546	018.0141	White ceramic gas diffuser;白色陶瓷分流器/26KD
● JDG0946		Black plastic gas diffuser;黑色塑料分流器/26KD

MIG 36

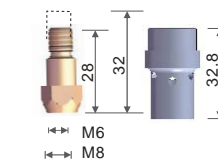

Code	Ref.	Description
○ JDG0073	014.0261	White plastic gas diffuser;白色塑料分流器/36KD
● JDG0007	014.0026	Black plastic gas diffuser;黑色塑料分流器/36KD
○ JDG0573	014.0023	White ceramic gas diffuser;白色陶瓷分流器/36KD
● JDV0029	142.0005	Contact tip holder M6x28mm;导电嘴座M6x28mm/36KD
● JDV0020	142.0020	Contact tip holder M8x28mm;导电嘴座M8x28mm/36KD
● JDV0697	142.0011	Contact tip holder M6x32mm;导电嘴座M6x32mm/36KD
● JDV0698		Contact tip holder M8x32mm;导电嘴座M8x32mm/36KD

MIG 40KD

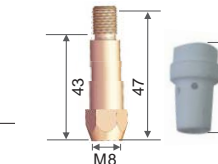

Code	Ref.	Description
● JDV0037	145.0021	Contact tip holder 40KD/M8/43mm;导电嘴座/40KD/M8/43mm
● JDV0038	145.0025	Contact tip holder 40KD/M8/47mm;导电嘴座/40KD/M8/47mm
○ JDG0008	015.0021	White plastic gas diffuser 40KD;白色塑料分流器 40KD
○ JDG0542	015.0023	White ceramic gas diffuser 40KD;白色陶瓷分流器 40KD



Note: About the registered trade mark, reference number of the model of the machine and spare parts, please see inner cover (company introduction)
注:关于在注册商标、机器及配件的参考编号的注解, 请见封面内页 (公司简介)

DIFFUSERS AND TIP HOLDERS

分流器及导电嘴座

SUITABLE FOR BINZEL



MIG 400/500

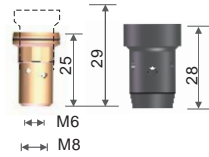

Code	Ref.	Description
● JDG0032	142.0022	Contact tip holder M8x25mm;导电嘴座M8x25mm/401D-501D
○ JDG0035	030.0145	White plastic gas diffuser;白色塑料分流器/401D-501D
● JDG0030	030.0037	Black plastic gas diffuser;黑色塑料分流器/401D-501D
● JDG0047	142.0008	Contact tip holder M6x25mm;导电嘴座M6x25mm/401D-501D
● JDG0048	142.0013	Contact tip holder M6x29mm;导电嘴座M6x29mm/401D-501D
● JDG0049	142.0027	Contact tip holder M8x29mm;导电嘴座M8x29mm/401D-501D
○ JDG0535	030.0190	White ceramic gas diffuser;白色陶瓷分流器/401D-501D
● JDG0851		Contact tip holder M8x25mm/COPPER;导电嘴座M8x25mm/紫铜/401D-501D
● JDG0857		Contact tip holder M8x29mm/COPPER;导电嘴座M8x29mm/紫铜/401D-501D

SUITABLE FOR TWECO



Type	Image	Code	Ref.	Description
TW1		JDG0074	51	Diffuser ;分流器
TW2		JDG0088	52	Diffuser ;分流器; (used with 32 insulator;用于32绝缘体)
		JDG0084	52-23	Diffuser ;分流器 (used with 23series nozzles or 34A;用于23系列或34A系列的喷嘴)
		JDG0075	52FN	Diffuser ;分流器
TW3-TW4		JDG0081	54A	Diffuser ;分流器
TW5		JDG0087	55	Diffuser ;分流器
		JDG0082	55SW	Diffuser ;分流器
		JDG0083	55H	Diffuser ;分流器



Note: About the registered trade mark, reference number of the model of the machine and spare parts, please see inner cover (company introduction)
注:关于在注册商标、机器及配件的参考编号的注解,请见封面内页(公司简介)

LINERS 送丝管

SUITABLE FOR BINZEL



EURO-TYPE / STEEL 欧式钢送丝管

Blue Φ 0.6-0.8mm
蓝色钢送丝管

Insulation steel liner Blue Φ 1.4x4.0x4.6mm

L	Code	Ref.	Pack
3.4m	JJD0511	124.0011	1
4.4m	JJD0517	124.0012	1
5.4m	JJD0518	124.0015	1
500m	JJD0076		1

Yellow Φ 1.2-1.6mm (flat)
黄色扁平钢送丝管

Insulation steel liner Yellow Φ 2.4x4.2x4.7mm

L	Code	Ref.	Pack
3.4m	JJD0501	124.0041	1
4.4m	JJD0507	124.0042	1
5.4m	JJD0508	124.0044	1
500m	JJD0028		1

Φ 0.8-1.0mm
无绝缘层钢送丝管

Steel liner Φ 1.4x4.5mm

L	Code	Ref.	Pack
3.5m	JJD0588	122.0005	1
4.5m	JJD0589	122.0007	1
5.5m	JJD0580	122.0009	1
500m	JJD0036		1

Φ 1.2-1.6mm
无绝缘层钢送丝管

Steel liner Φ 2.5x4.5mm

L	Code	Ref.	Pack
3.5m	JJD0591	122.0056	1
4.5m	JJD0597	122.0060	1
5.5m	JJD0598	122.0073	1
500m	JJD0027		1

EURO-TYPE / TEFLON 欧式特氟龙送丝管

Blue Φ 0.6-0.9mm
蓝色特氟龙送丝管

Teflon liner Φ 1.5 x4mm

L	Code	Ref.	Pack
3.5m	JJD0111	126.0005	1
4.5m	JJD0117	126.0008	1
5.5m	JJD0118	126.0011	1
200m	JJD0081		1

Red Φ 1.0-1.2mm
红色钢送丝管

Insulation steel liner Red Φ 2x4.0x4.6mm

L	Code	Ref.	Pack
3.4m	JJD0571	124.0026	1
4.4m	JJD0577	124.0031	1
5.4m	JJD0578	124.0035	1
500m	JJD0029		1

Yellow Φ 1.2-1.6mm (rounded)
黄色钢送丝管

Insulation steel liner Yellow Φ 2.5x4.5x4.7mm

L	Code	Ref.	Pack
3.4m	JJD0561		1
4.4m	JJD0567		1
5.4m	JJD0568		1
500m	JJD0023		1

Φ 1.0-1.2mm
无绝缘层钢送丝管

Steel liner Φ 2.0x4.5mm

L	Code	Ref.	Pack
3.5m	JJD0582	122.0031	1
4.5m	JJD0583	122.0036	1
5.5m	JJD0584	122.0039	1
500m	JJD0020		1

Red Φ 1.0-1.2mm
红色特氟龙送丝管

Teflon liner Φ 2x4mm

L	Code	Ref.	Pack
3.5m	JJD0171	126.0021	1
4.5m	JJD0177	126.0026	1
5.5m	JJD0178	126.0028	1
200m	JJD0075		1



Note: About the registered trade mark, reference number of the model of the machine and spare parts, please see inner cover (company introduction)
注:关于在注册商标、机器及配件的参考编号的注解,请见封面内页(公司简介)

LINERS 送丝管



SUITABLE FOR BINZEL

EURO-TYPE / TEFLON 欧式特氟龙送丝管

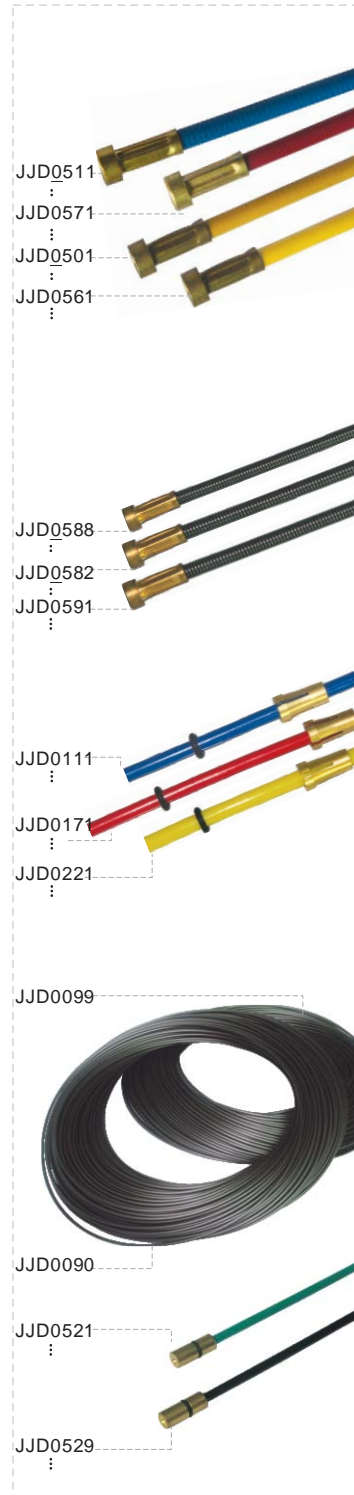

Yellow Φ 1.2-1.6mm 黄色特氟龙送丝管

Teflon liner Φ 3.0x4.5mm

L	Code	Ref.	Pack
3.5m	JJD0221	126.0039	1
4.5m	JJD0227	126.0042	1
5.5m	JJD0228	126.0045	1
200m	JJD0088		1

Blue Φ 0.6-0.9mm 蓝色特氟龙+铜送丝管

Teflon liner Φ 4.0x1.5mm+terminator

L	Code	Ref.	Pack
3.5m	JJD0271		1
4.5m	JJD0277		1
5.5m	JJD0278		1

Red Φ 1.0-1.2mm 红色特氟龙+铜送丝管

Teflon liner Φ 2.0x4.0mm+terminator

L	Code	Ref.	Pack
3.5m	JJD0276		1
4.5m	JJD0272		1
5.5m	JJD0273		1

Yellow Φ 1.2-1.6mm 黄色特氟龙+铜送丝管

Teflon liner Φ 3.0 x 4.5 mm+terminator

L	Code	Ref.	Pack
3.5m	JJD0291		1
4.5m	JJD0297		1
5.5m	JJD0298		1

EURO-TYPE / GRAPHITE 欧式石墨尼龙送丝管

Φ 1.0-1.2mm 石墨尼龙送丝管+铜送丝管

Graphite liners Φ 4.0 x 2.0mm +Terminator

L	Code	Ref.	Pack
3.5m	JJD0286		1
4.5m	JJD0282		1
5.5m	JJD0283		1
200m	JJD0099		1

Φ 1.2-1.6mm 石墨尼龙送丝管+铜送丝管

Graphite liners Φ 4.5x2.7mm+Terminator

L	Code	Ref.	Pack
3.5m	JJD0202		1
4.5m	JJD0203		1
5.5m	JJD0204		1
200m	JJD0090		1

Φ 1.2-1.6mm 石墨尼龙送丝管

Graphite liners Φ 4.7x2.7mm

L	Code	Ref.	Pack
200m	JJD0060		1

SUITABLE FOR PAN

PAN-TYPE 日式送丝管

Black Φ 0.8-1.0mm 黑色钢送丝管

Insulation steel liner Φ 1.8x4.2x5.0mm

L	Code	Ref.	Pack
3.1m	JJD0562		1
4.1m	JJD0563		1
5.1m	JJD0564		1
500m	JJD0021		1

Green Φ 1.0-1.2mm 绿色钢送丝管

Insulation steel liner Φ 1.8x4.6x5.2mm

L	Code	Ref.	Pack
3.5m	JJD0521		1
4.5m	JJD0527		1
5.5m	JJD0528		1
500m	JJD0062		1

Black Φ 1.2-1.6mm 黑色钢送丝管

Insulation steel liner Φ 2x5x5.6mm

L	Code	Ref.	Pack
3.5m	JJD0529		1
4.5m	JJD0520		1
5.5m	JJD0526		1
500m	JJD0072		1



Note: About the registered trade mark, reference number of the model of the machine and spare parts, please see inner cover (company introduction)
注:关于在注册商标、机器及配件的参考编号的注解, 请见封面内页(公司简介)

LINERS 送丝管



SUITABLE FOR TWECO



Amp	L(in/m)	Code	Ref.	Wire	Pack
160A	15"(4.6m)	JJD0754	23-40-15	0.23"(0.6)	1
	15"(4.6m)	JJD0755	35-40-15	0.030"-0.035"(0.8-0.9)	1
	15"(4.6m)	JJD0015	45-40-15	0.040"-0.045"(1.0-1.2)	1
180-250A	15"(4.6m)	JJD0811	42-23-15	0.23"(0.6)	1
	11"(3.4m)	JJD0077-03		0.030"-0.035"(0.8-0.9)	1
	15"(4.6m)	JJD0077	42-3035-15	0.030"-0.035"(0.8-0.9)	1
300-450A	11"(3.4m)	JJD0078-03		0.035"-0.045"(0.9-1.2)	1
	15"(4.6m)	JJD0782	44-3545-15	0.035"-0.045"(0.9-1.2)	1
	11"(3.4m)	JJD0079-03		0.052"-1/16"(1.3-1.6)	1
	15"(4.6m)	JJD0079	44-116-15	0.052"-1/16"(1.3-1.6)	1
	11"(3.4m)	JJD0787-03		5/64"(2.0)	1
	15"(4.6m)	JJD0787	44-564-15	5/64"(2.0)	1
500-650A	15"(4.6m)	JJD0877	44-332-15	3/32"(2.4)	1
	15"(4.6m)	JJD0082	45-3545-15	0.035"-0.045"(0.9-1.2)	1
	15"(4.6m)	JJD0083	45-116-15	0.052"-1/16"(1.3-1.6)	1
	15"(4.6m)	JJD0084	45-564-15	5/64"(2.0)	1
15"(4.6m)	JJD0097	45-332-15	3/32"(2.4)	1	

Amp	L(in/m)	Code	Ref.	Wire	Pack
160A	10"(3m)	JJD0991	35TF-40-10	0.030"-0.035"(0.8-0.9)	1
	10"(3m)	JJD0997	35TF-40-10	0.040"-3/64"(1.0-1.2)	1
180-250A	15"(4.6m)	JJD0998	42N-3545-15	0.036"-3/64"(0.8-1.2)	1
	15"(4.6m)	JJD0999	44N-3545-15	0.036"-3/64"(0.8-1.2)	1
300-450A	15"(4.6m)	JJD0990	44N-116-15	1/16"(1.6)	1
	15"(4.6m)	JJD0267	45N-116-15	0.030"-3/64"(0.8-1.2)	1
	15"(4.6m)	JJD0990	45N-116-15	1/16"(1.6)	1



Note: About the registered trade mark, reference number of the model of the machine and spare parts, please see inner cover (company introduction)
注:关于在注册商标、机器及配件的参考编号的注解, 请见封面内页(公司简介)

COMPLETE CABLES 电缆组



Gas cooled 气冷

EURO



PAN



Water cooled 水冷

EURO



Assembly 水电缆组

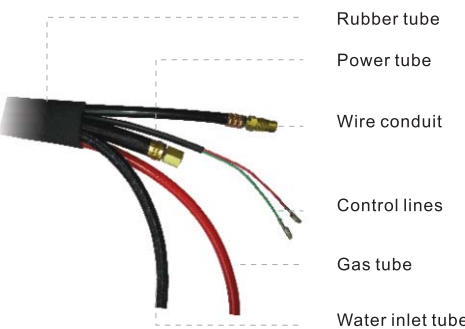

EURO TYPE 欧式

15AK

L	Code	Ref.	Pack
3m	JDO0674		1
4m	JDO0687		1
5m	JDO0688		1

26KD

L	Code	Ref.	Pack
3m	JDO0607		1
4m	JDO0608		1
5m	JDO0600		1

40KD

L	Code	Ref.	Pack
3m	JDO0620		1
4m	JDO0626		1
5m	JDO0622		1

PAN TYPE 日式

PAN180

L	Code	Ref.	Pack
3m	JDO0121		1
4m	JDO0127		1
5m	JDO0128		1

PAN500

L	Code	Ref.	Pack
3m	JDO0191		1
4m	JDO0197		1
5m	JDO0198		1

Power cable 水电缆

L	Code	Ref.	Pack
3m	JLU0075		1
4m	JLU0081		1
5m	JLU0087		1

Wire conduit 送丝管

L	Code	Ref.	Pack
3m	JLI0038		1
4m	JLI0039		1
5m	JLI0030		1

Water inlet tube 进水管

L	Code	Ref.	Pack
3m	JLI0032		1
4m	JLI0033		1
5m	JLI0034		1

24-25KD

L	Code	Ref.	Pack
3m	JDO0675		1
4m	JDO0680		1
5m	JDO0686		1

36KD

L	Code	Ref.	Pack
3m	JDO0681		1
4m	JDO0683		1
5m	JDO0684		1

PAN350

L	Code	Ref.	Pack
3m	JDO0199		1
4m	JDO0190		1
5m	JDO0196		1

EURO TYPE 欧式

Water cooled cable 240/400/500

L	Code	Ref.	Pack
3m	JDE0078		1
4m	JDE0079		1
5m	JDE0070		1

Gas tube 气管

L	Code	Ref.	Pack
3m	JLI0041		1
4m	JLI0047		1
5m	JLI0048		1

Control wire 控制线

L	Code	Ref.	Pack
3m	JIR0601-03		1
4m	JIR0601-04		1
5m	JIR0601-05		1

Rubber tube 橡胶外管

L	Code	Ref.	Pack
3m	JDL0716		1
4m	JDL0712		1
5m	JDL0713		1

CENTRAL ADAPTORS 中央插头插座

SUITABLE FOR TWECO

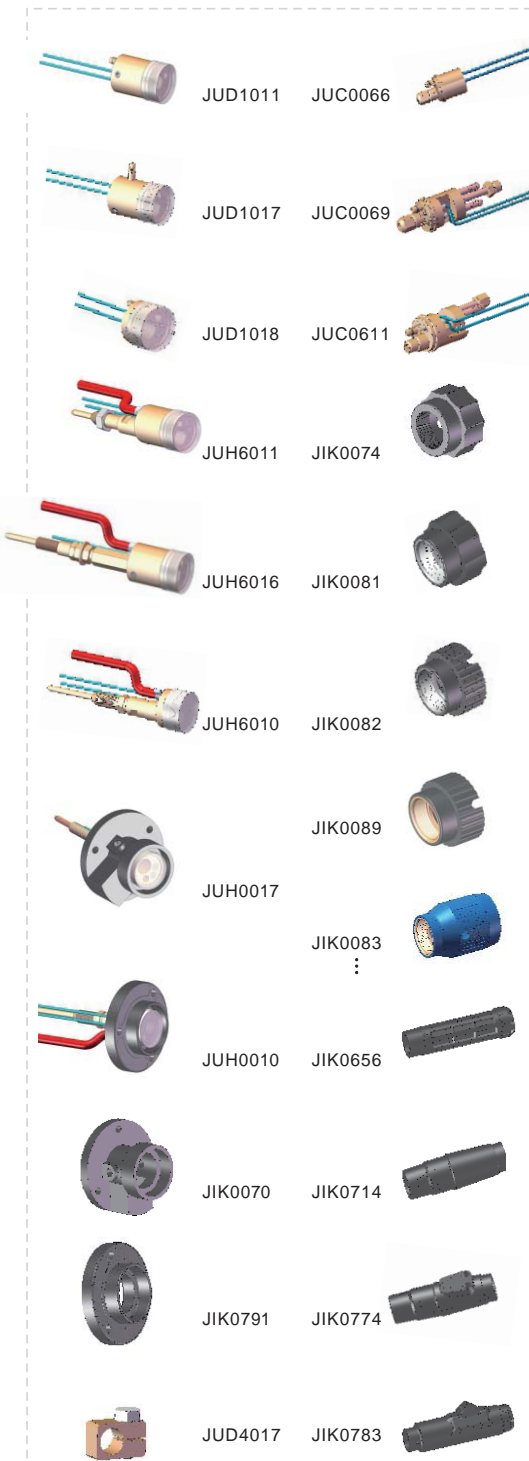

Code	Ref.	Description
JUC0066		Euro central adaptor body/spring pins/with Nut; 欧式中央接头弹性针/带螺母
JUC0069		Water euro central adaptor body/spring pins/with Nut; 欧式水冷中央接头弹性针/带螺母
JUC0611		Euro central adaptor/water/tynos/spring pin; 欧式中央接头水冷/tynos/弹性针
JUD1011	501.0168	Euro central adaptor femaler/machine side-axial; 欧式中央插座/轴向
JUD1017		Euro central adaptor femaler radial; 欧式中央插座/纵向
JUD1018		Mini euro central adaptor fdmale-axial; 迷你欧式中央插座/轴向
JUD4017		Current clamp 16mm; 电缆压块 16mm
JUH0017		Central adaptor female machine side; 欧式中央插座/机器端
JUH0010		Mini central adaptor female machine side; 迷你欧式中央插座/机器端
JUH6011		Euro central adaptor female machine side; 迷你欧式中央插座/机器端
JUH6016		Euro central adaptor female machine side; 迷你欧式中央插座/机器端
JUH6010		Mini euro central adaptor female machine side; 迷你欧式中央插座/机器端
JIK0074		Gun plug nut/plastic nut; 焊枪锁紧螺母/塑料螺纹
JIK0070	501.0616	Plastic housing; 塑料法兰
JIK0081		Gun plug nut; 焊枪锁紧螺母
JIK0082	500.0213	Gun plug nut BZ type; 焊枪锁紧螺母/BINZEL式
JIK0083		Gun plug nut new blue; 焊枪锁紧螺母(新)/蓝色
JIK0084		Gun plug nut new red; 焊枪锁紧螺母(新)/红色
JIK0085		Gun plug nut new orange; 焊枪锁紧螺母(新)/橙色
JIK0089		Gun plug nut/BZ type/brass screw; 焊枪锁紧螺母/BINZEL式铜螺母
JIK0656		Back box hole; 后把套
JIK0714		Back box hole; 后把套
JIK0774		Back box hole/water; 后把套/水冷
JIK0791		Plastic housing/MINI; 塑料法兰/迷你
JIK0783		Back box hole/water; 后把套/水冷
JIR0211		Spring pin with wire and insulator for air cooling; 气冷接头用弹性针
JIR0218		Spring pin with wire and insulator for water cooling; 水冷接头用弹性针
JIR0789		Control wire with pin/0.5mm ² /800mm; AMP控制线/0.5mm ² /800mm
JLI0081		Blue wired hose Φ 5x8mm; 增强网纹管 Φ 5x8mm/蓝色
JLI0086		Red wired hose Φ 5x8mm; 增强网纹管 Φ 5x8mm/红色
JLI0073		Black wired hose Φ 5x8mm; 增强网纹管 Φ 5x8mm/黑色
JLI0098		PU tube Φ 6x8mm/high temperture; PU管 Φ 6x8mm/耐高温
JGU0734		Clamp Φ 7.0mm; 卡箍 Φ 7.0mm
JGU0745	171.0002	Clamp Φ 8.7mm; 卡箍 Φ 8.7mm
JGU0746		Clamp Φ 10.5mm; 卡箍 Φ 10.5mm
JGU0748	173.0001	Clamp Φ 9.5mm; 卡箍 Φ 9.5mm



more clamps at request
提供多种尺寸卡箍



Note: About the registered trade mark, reference number of the model of the machine and spare parts, please see inner cover (company introduction)
注: 关于在注册商标、机器及配件的参考编号的注解, 请见封面内页 (公司简介)



Note: About the registered trade mark, reference number of the model of the machine and spare parts, please see inner cover (company introduction)
注: 关于在注册商标、机器及配件的参考编号的注解, 请见封面内页 (公司简介)

